

# INSTRUCTION MANUAL

## CL-100 Centre Lathe (415V) 660 x 2000mm Turning Capacity

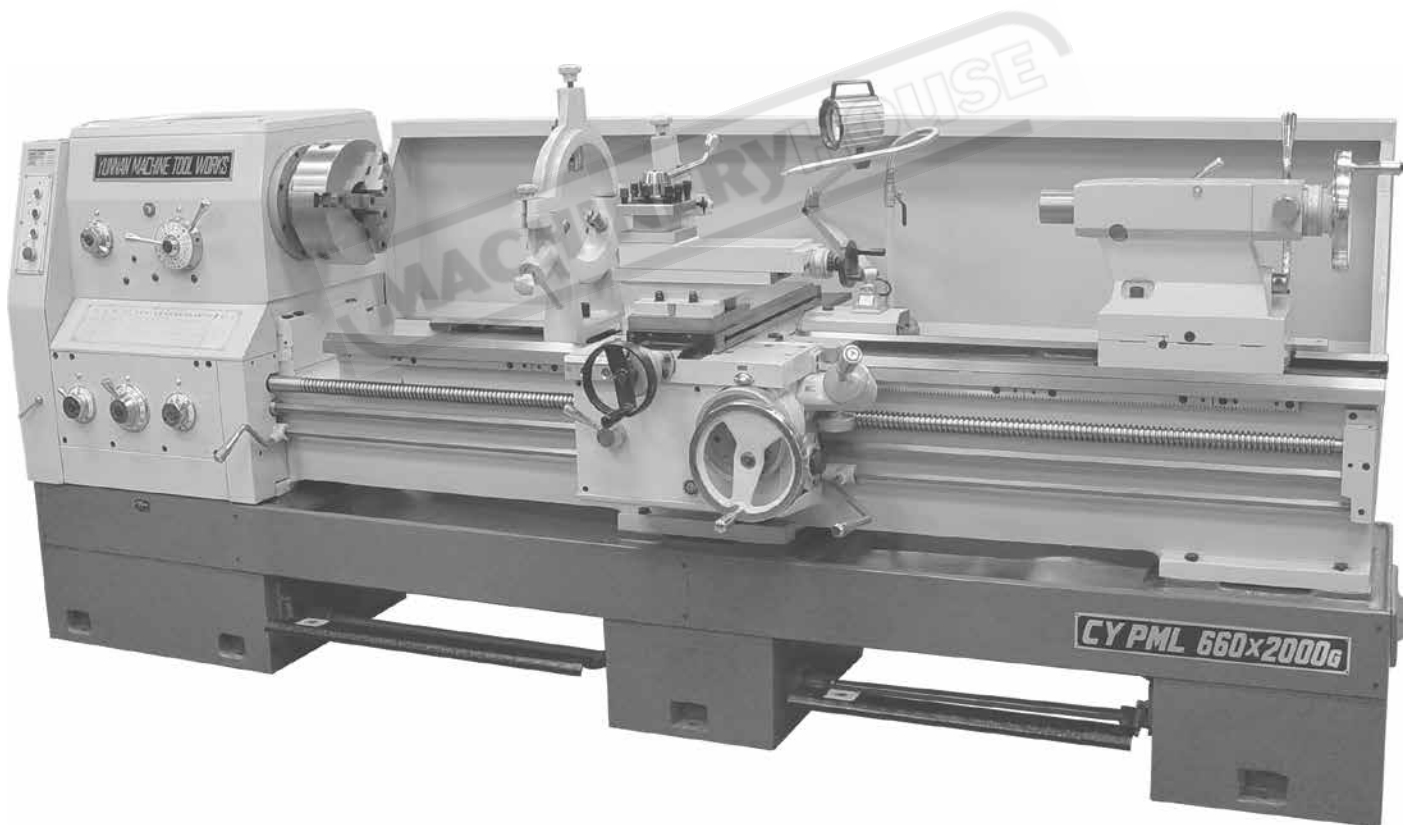

L172

## **CL SERIES HORIZONTAL LATHE**

# **OPERATION MANUAL**



• 云南机床厂

---

## Contents

➤	I . Applications.....	2
➤	II . Specifications.....	3
➤	III . Slinging, handling and installation .....	6
➤	IV . Operating System .....	11
➤	V . Drive system .....	20
➤	VI . Electrical System .....	23
➤	VII . Lubricating system.....	34
➤	VIII . Cooling system .....	35
➤	IX . Construction and adjustments .....	36
➤	X . Maintenance and service.....	41
➤	XI . Digital display unit.....	47
➤	XII . Special subordinate equipments.....	50
➤	X III . Attachments .....	57
➤	X IV . Operating tools.....	59
➤	X V . Optional equipments and function assemblies .....	61
➤	Addenda:                                      Emergency brake.....	63

• 云南机床厂

---

**CL Series Horizontal Universal Lathe, which includes three kinds of different Maximum swivel diameter over the bed, 21 types of feedrates will be gained through the combinations of the first main parameters with seven kinds of different maximum workpiece length, the second main parameters, (the numbers before and after symbol "×" represent the maximum swivel diameter and the length of workpieces in millimeters). In accordance with the requirements of users, the lathe may be supplied for different feedrates (in metric and English system), operation modes (left or right, according to the operating handwheel position on electrical cabinet), power voltage, frequency (shown on the capacity plate of electrical cabinet), various types of spindle nose, and may be equipped with saddle, digital display and other subordinated equipments if required.**

**For the safety of operation and fulfillment of your task, read this operating manual carefully and thoroughly before starting the machine, to get full understanding of the related descriptions regarding your serial No. of the machine and model.**

MACHINERYHOUSE

• 云南机床厂

---

## I. Applications

**On ferrous or non-ferrous metals, plastics or synthetic rubber workpieces can these universal lathes, either used in roughing or finishing, perform all basic turning operations, such as external and internal cylindrical, conical or any kind of rotary surfaces, end-facing, grooving as well as thread cutting in metric, whitworth, module and diametrical pitch, including drilling, reaming, and oil-groove broaching etc.**

**Machining accuracy of roundness error within 0.01mm, cylindricity error within 0.01mm on measured length of 100mm, the surface finish is not less than Ra 3.2 $\mu$ m, and threadpitch error within 0.06mm on measured length of 300mm.**

**Lathes of CYPML-series are suitable for production and maintenance operations in single job and small batch works in machine shops, tool-rooms, maintenance depots and laboratories.**

MACHINERYHOUSE

## II. Specifications

### A. Constructure parameters

#### (1) Max. bar diameter admitted. (according to different diameters)

**Db. (Diameter over the bed)** 500mm(20") 630mm(25") 660mm(26")

**Dt. (Diameter over cross slide)** 300mm(12") 400mm(14") 430mm(15")

**Dg. (Diameter in gap)** 710mm(28") 840mm(33") 870mm(34")

#### (2) Max. Length of bar

**Lc: Distance between the end of spindle to tailstock (according to various length of the machine).**

750mm(30")、1000mm(40")、1500mm(60")、2000mm(80")、3000mm(120")、4000mm(160")、5000mm(200")

**Lg (Distance between spindle and gap, available with gap)**

240mm (9")

#### (3) Spindle nose (according to the type of spindle nose)

A8, A11, D8 or D11.

**Diameter of spindle bore: 105mm (4")**

#### (4) Tailstock

**Diameter of tailstock sleeve** 75mm (2 61/64")

**Taper bore of the tailstock** M5

**Travel of tailstock** 150mm (6")

**travel of the cross slide in transverse**  $\pm 15\text{mm}(19/32")$

#### (5) Toolslide

**Max. cross section of the tool admitted** 25mm×25mm(1"×1")

**Vertical distance between the tool supporting surface and spindle center line** 28mm (1 7/64")

**rotary scales of middle toolslide**  $\pm 90^\circ$

**Max. travel of the top toolslide**

**Db(max.swing over bed) Max.travel of top toolslide.**

**Db =500mm (20")** 150mm (5 38/64")

**Db ≥630mm(25")** 190mm(7 31/64")

**Max. travel of low tool slide**

• 云南机床厂

**Db (max. swing over bed) max. travel of low toolslide**

**Db =500mm (20")                      300mm (11 13/16")**

**Db ≥630mm(25")                      370mm(14 9/16")**

**B. Moving parameters**

**(1) Spindle running**

**Steps    24**

**speeds rang                                      6~1120r/min**

**(2) Manual movement of tailstock quill**

**Shifts    2**

**Shifting ratio                                      1:1 decrease ratio 2.5:1**

**(3) Toolslide movements**

**Basic feeds: longitudinal feeds 0.063~2.52mm/r(0.0025~0.099"/r)**

**transversal feeds 0.027~1.07mm/r(0.00054~0.0215"/r)**

**Amplified feeds: longitudinal feeds 2.86~6.43mm/r(0.113~0.253"/r)**

**transversal feeds 1.21~2.73mm/r(0.024~0.055"/r)**

**Rapid traveling speed: longitudinal 4.5m/min (15ft/min) (50Hz) or**

**5.4m/min (18ft/min) (60Hz)**

**transversal 1.9m/min(3.2ft/min) (50Hz) or**

**2.3m/min (3.8ft/min) (60Hz)**

**(4) Varieties, steps and range of threading (according to different measuring systems as follows).**

**metric lathes: 46 inch thread leads                      1~244mm**

**45 inch thread leads                      28~1/8 t/in**

**42 module thread leads                      0.5~112m**

**45 diametrical pitch of lends                      56~1/4 D.P.**

**inch lathes: 46 inch thread leads                      28~1/8 t/in**

**46 metric thread leads                      1~224mm**

**45 diametrical pitch of leads                      56~1/4 D.P.**

**42 module threads leads                      0.5~112m**

**C. Power parameters**

**(1) A.C. power supply (on request)**

**Frequency                      50Hz or 60Hz**

• 云南机床厂

**Phase**                    **three-phase**  
**Voltage**                **220V, 380V, 420V or 440V**

**(2) Motor power**

**Main drive motor (supplied on request):**

**7.5KW (10HP), 11KW (15HP) or 15KW (20HP)**

**Rapid travel motor of toolslide:                    250W (0.34HP)**

**Coolant pump motor (flow rate 25L/min)    90W (0.12HP)**

**(3) Permissible cutting edge**

**Max main cutting edge:                    13700N (3080Ibf)**

**Max feedrates:                                3400 N (765Ibf)**

**(4) Motive consumption (10KWA, 14KWA or 19KWA according to different main drive motor.**

**D. outline dimensions. (L.W.H.)**

**(1) Length of the machine: according to the Max. workpiece length  $l_c$ .**

**( $L_{min}$  travel lever of the tailstock quill within the length of the machine;**

**$L_{max}$ . after the max. workpiece length)**

**$L_c=750\text{mm}[30"]$ :  $L_{min}=2276\text{mm}[89\ 39/64"]$      $L_{max}=2432\text{mm}[95\ 3/4"]$**

**$L_c=1000\text{mm}[40"]$ :  $L_{min}=2526\text{mm}[99\ 29/64"]$      $L_{max}=2682\text{mm}[105\ 19/32"]$**

**$L_c=1500\text{mm}[60"]$ :  $L_{min}=3026\text{mm}[119\ 9/64"]$      $L_{max}=3182\text{mm}[125\ 9/32"]$**

**$L_c=2000\text{mm}[80"]$ :  $L_{min}=3526\text{mm}[138\ 52/64"]$      $L_{max}=3682\text{mm}[144\ 61/64"]$**

**$L_c=3000\text{mm}[120"]$ :  $L_{min}=4526\text{mm}[178\ 6/32"]$      $L_{max}=4682\text{mm}[184\ 21/64"]$**

**$L_c=4000\text{mm}[160"]$ :  $L_{min}=5526\text{mm}[217\ 9/16"]$      $L_{max}=5682\text{mm}[223\ 45/64"]$**

**$L_c=5000\text{mm}[200"]$ :  $L_{min}=6526\text{mm}[256\ 59/64"]$      $L_{max}=6682\text{mm}[263\ 5/64"]$**

**(2) width of the machine  $B$ : according to the Max.swing over bed, when the lower toolslide and the traverse motion handlever of toolslide is in minimum condition.**

**$D_b = 500\text{mm}[20"]$  :  $B_{min}=998\text{mm}[39\ 19/64"]$      $B_{max}=1213\text{mm}[47\ 3/4"]$**

**$D_b \geq 630\text{mm}[25"]$ :  $B_{min}=1083\text{mm}[42\ 41/64"]$      $B_{max}=1298\text{mm}[51\ 7/64"]$**

**(3) Height of the machine  $H$ : according to max.swing over bed. ( $D_b$ )**

**( $H_{min}$  means lathe without saddle;  $H_{max}$  means lathe with saddle and faceplate.)**

**$D_b=500\text{mm}[20"]$ :  $H_{min}=1350\text{mm}[53\ 5/32"]$      $H_{max}=1440\text{mm}[56\ 11/16"]$**

**$D_b=630\text{mm}[25"]$ :  $H_{min}=1415\text{mm}[55\ 45/64"]$      $H_{max}=1590\text{mm}[62\ 19/32"]$**

**$D_b=660\text{mm}[26"]$ :  $H_{min}=1430\text{mm}[56\ 19/64"]$      $H_{max}=1605\text{mm}[63\ 3/16"]$**



---

### III. Slinging, handling and installation

#### (A) Slinging and handling

When lifting the packed lathe, rope must be slung in accordance with the marks on the packing case. In transporting and unloading don't let it too much be tilted and the case should not be perused or shocked violently so as not to damage the casebottom or the sideplates. Placing the case on edged bodies or the sideplates. Placing the case on edged bodies or upside down is strictly forbidden.

Follow the arrangements shown on Fig.3-1(page 8) to locate the rope, put soft pads or fell between ropes and the painted surface of lathe and care must be taken not to damage the lathe when lifting. By moving the saddle position, smooth slinging and handling can be realized.

#### (B) Opening the case

After the case is opened, inspect the outward condition of the machine immediately and check up the assessors and tools according to the packing list.

#### (C) Installation

The machine has been checked and tested before delivery, yet installation should be carried out correctly to insure the machining accuracy for long time.

As shown on Fig.3-1(page 8), the lathe is supported on preconcreted base by a number of foundation wedges. Adjust the wedges by using a precision level to keep the longitudinal level not over 0.04/1000mm, and the transversal lever not over 0.03/1000mm.

Whenever an approximate leveling is being finished, full up the foundation bolt housings with concrete to fix the bolts. After it is fully dry and hardened, then carry on an accurate leveling, adjust the wedges gradually and tighten up the foundation boll nuts evenly until the accurate leveling is obtained. Finally pour cement between the ground and the base to fix the foundation wedges, seal the surrounding area of the cabinet legs and smooth the ground surface.

#### (D) Cleaning

Carefully remove the anti-corrosion coatings on all parts with kerosene. Wash the inner part of the headstock with heated kerosene. All capillary woolen yarns must be

• 云南机床厂

---

cleaned attentively one by one. Smear the sliding guide ways, leadscrew, feed shaft etc. The machine are cleared thoroughly and perfectly, then give a general lubrication sufficiently according to the lubricating system diagram(Fig.7-1).

**(E) Trial running**

Before putting the machine into trial running, the operator should carefully read through every section of the manual, understand the construction of the machine and acquainted himself with the position of all the operation elements and the details of operation.

Check the oiling condition of all the lubricating points. Check the working condition of each part of the machine manually.

Before power is supplied, check the electrical system to make sure whether the system is in good condition and whether motor is damped. After power is supplied, check whether the main motor is rotating in clockwise direction.

If everything is O.K. a trial running will be carried on. In the beginning of the trial the machine must be run at a minimum speed for some time and then gradually be accelerated. While the machine is in trial running, check the lubricating, electrical and cooling system as well as operating condition of each part attentively.

Only when the machine is in normally operating, well-lubricating, reliable manipulating and sensitively braking, can it start working.

• 云南机床厂

Fig 3-1 1/Lc=750[30" ]~1500[60" ]

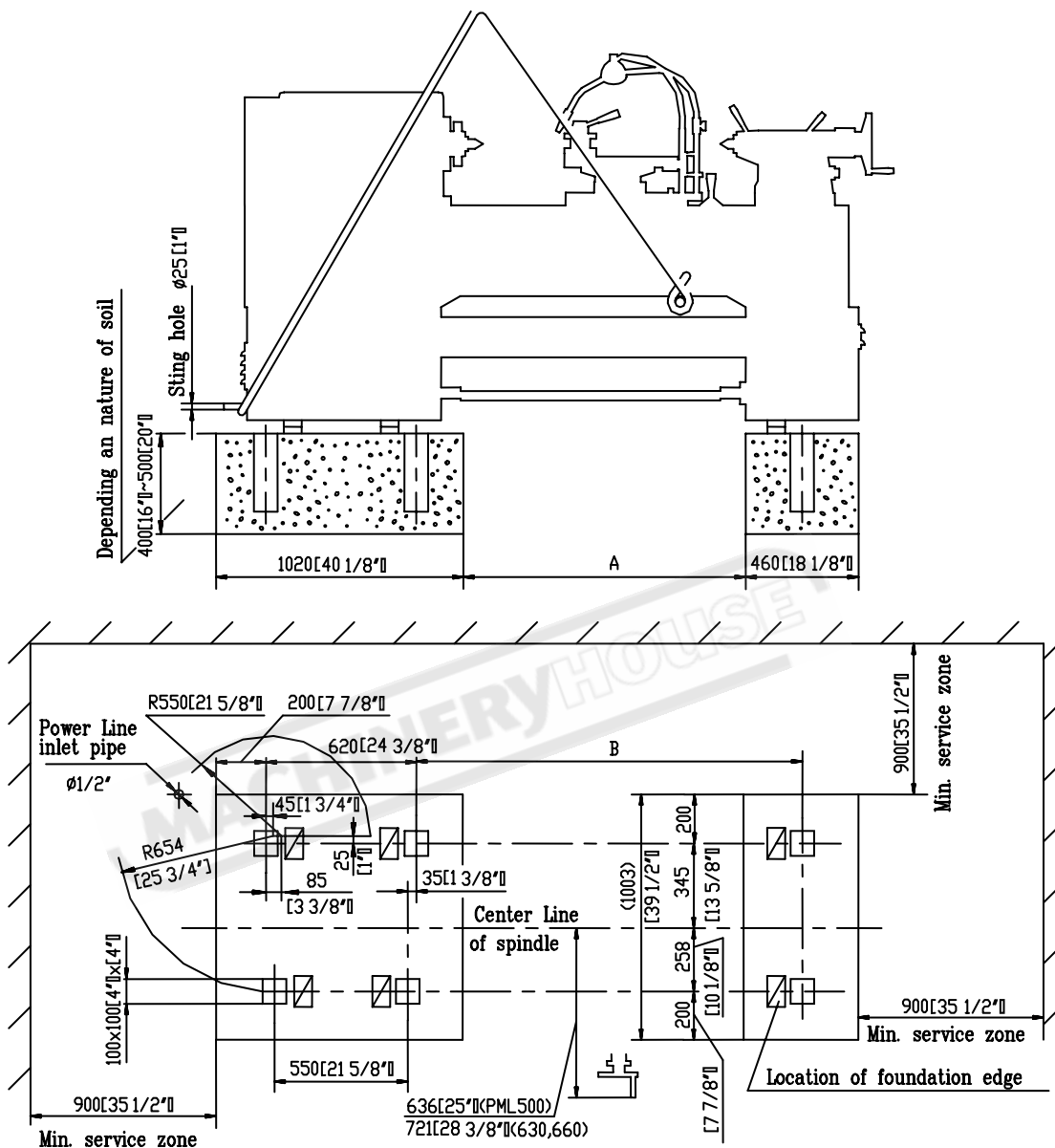

Max. Length of workpiece

	750 [30"]	1000 [40"]	1500 [60"]
A	875 [34 1/2"]	1125 [44 1/4"]	1625 [64"]
B	1305 [51 3/8"]	1555 [61 1/4"]	2055 [80 7/8"]

Fig. 3-1 1/ Lc=750[30" ]~1500[60" ]

• 云南机床厂

Fig 3-1 2/Lc=2000[80" ]~3000[120" ]

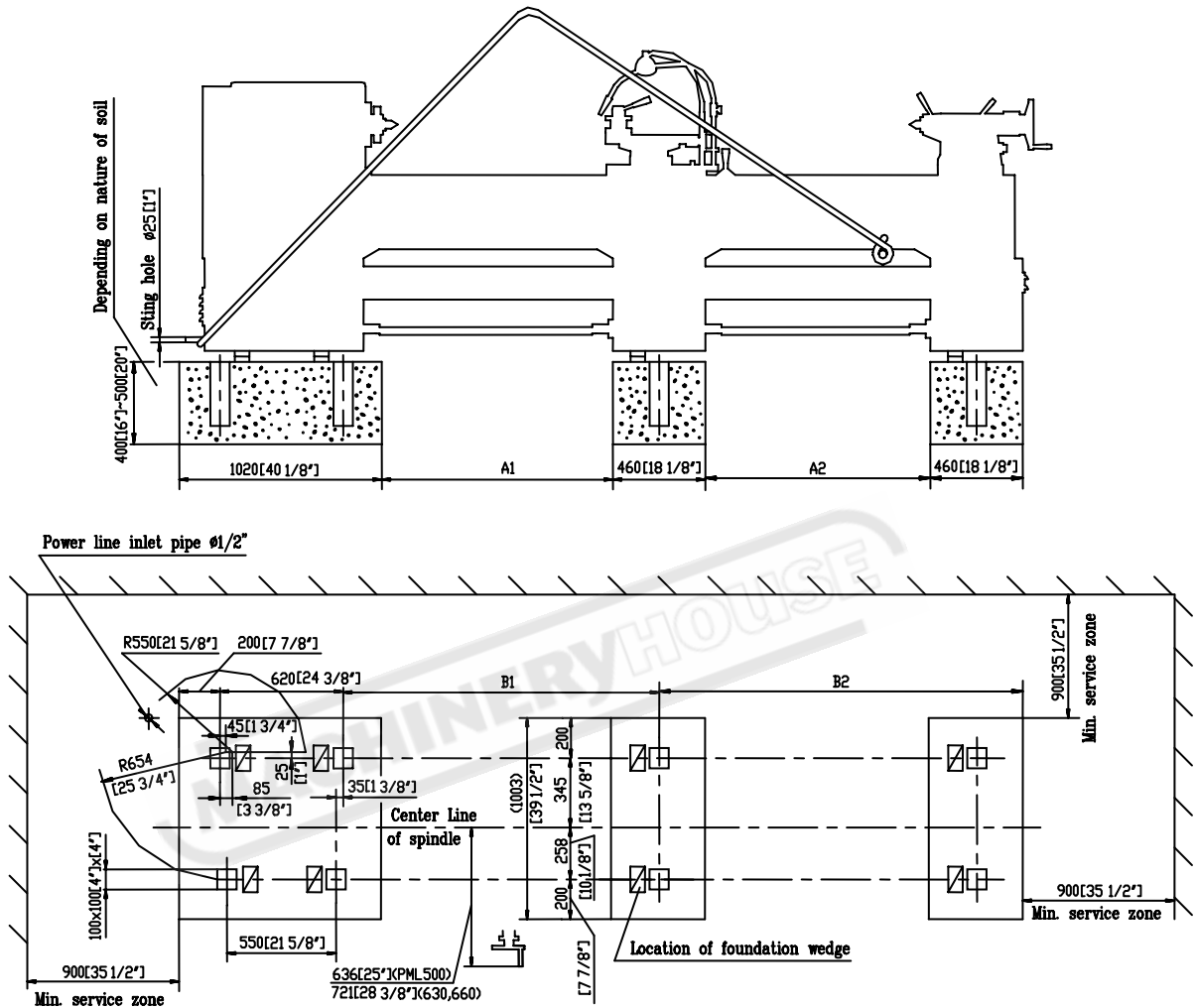

Max. Length of workpiece

	A1	A2	B1	B2
2000[80"]	855[33 5/8"]	810 [31 7/8"]	1285[50 5/8"]	1270[50"]
3000[120"]	1275[50 1/4"]	1390[54 3/4"]	1705[67 1/8"]	1850[72 7/8"]

Fig. 3-1 2/ Lc=2000[80" ]~3000[120" ]

• 云南机床厂

Fig.3-1 3/Lc=4000[160"] ~5000[200"]

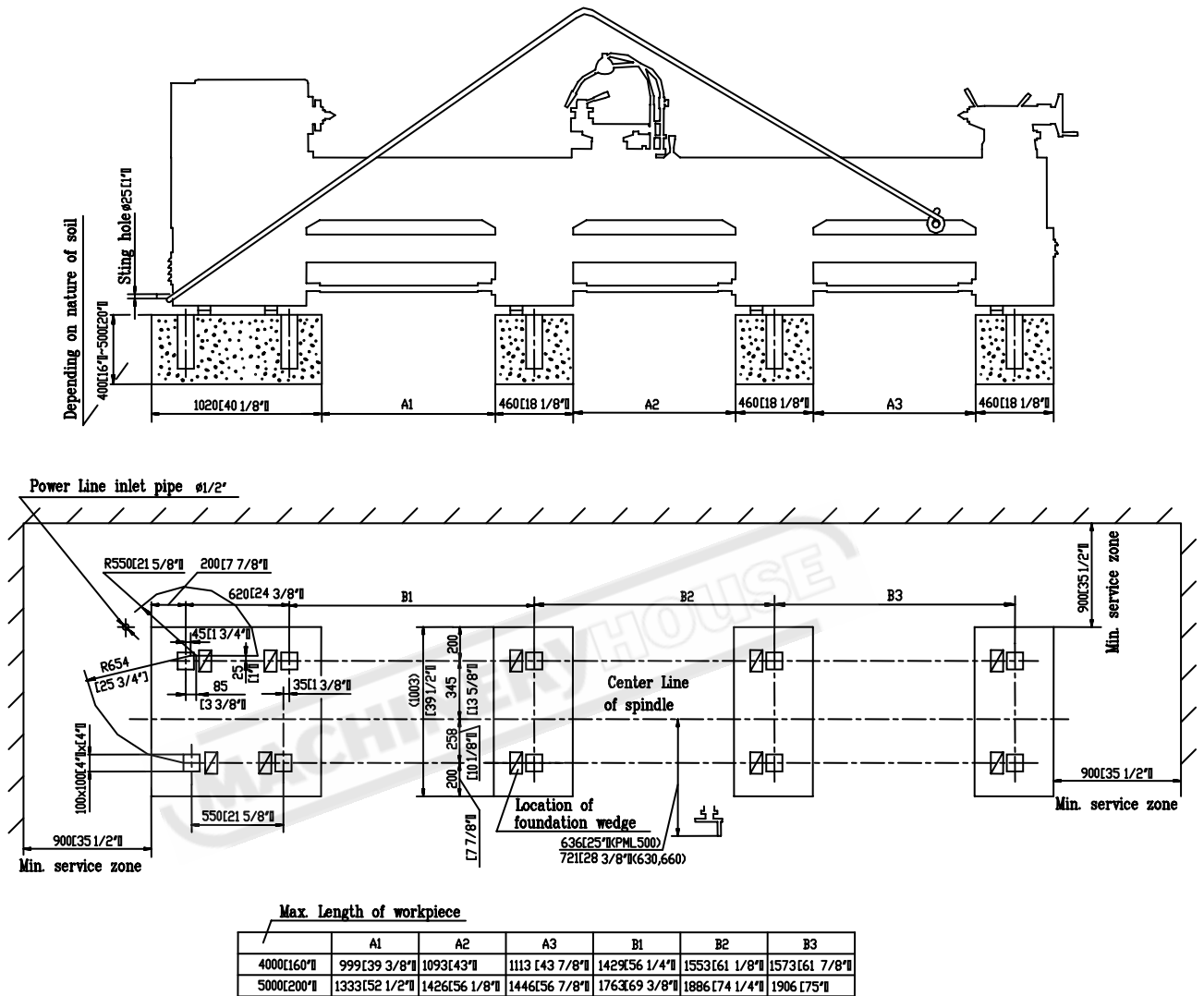

Fig. 3-1 3/ Lc=4000[160"]~5000[200"]

## IV. Operating System

### (A) Operating elements

The operating elements and their location are shown in Fig.4-1.

### (B) Change spindle speeds

The speed of the spindle is regulated by gear shift lever (No.8) and (No.9)

Matching the eight gear position of lever No.8 with the three gear positions (except the white point position) of lever No.9 according to the same color, 24 steps of forward and reverse rotary speeds can be achieved. (as shown on Table 4-1)





When lever No.9 is in white position, the spindle being in free state without mechanical transmission, automatic feeding motion resulted from spindle drive will not be produced.

### (C) Change the threadpitch and feedrates

Selection of threadpitch and feedrates is carried out by actuation handwheel No.4, handwheel No.5 of thread leads, shifting lever No.6 of basic threadpitch, shifting handwheel No.7 of multiplying threadpitch. By matching the above levers and handwheels, various threadpitches and feedrates can be acquired. The transposing gears need to be changed only in the case that certain inch threadpitches and the second kind of turning leadscrew and worm rod are used.

(1) Normal and amplified pitches, forward and reversing feed handwheel (4) can change and amplify the pitch and the direction of thread or change the feedrate. Since the apron is adapting a one-way overrunning clutch for transmission, so automatic feedrate of the toolslide can be carried out only when the handwheel (4) is in "right-hand" position.

The locations of the handwheel are described as follows.

-  - shows right-hand normal pitch and feedrates
-  - shows left-hand normal pitch; (no feedrates)
-  - shows right-hand amplified pitch and amplified feedrates
-  - shows left-hand amplified pitch (no feedrates)
-  - machine's cut-off feeding motion chain

• 云南机床厂

**(2) The major function of thread-type handwheel (5) is to select the required type of thread, and certainly can be used to change the feedrates as well.**

The locations of the handwheels are descriptor as below:

- t** —shows metric thread cutting
- n** —shows whitworth thread cutting
- m** —shows module thread cutting
- DP** —shows diametrical pitch thread cutting
- ⊣** —shows the transmission is not passing through the mechanism of thread type.

**(3) The basic gear-ratio selection lever(6), being actuated following the sequence from No.1 to No.15 on the circular index plate, can change the threadpitches or feedrates from small to big. The sequence number from 1 to 15 on the circular index plate represent the swiveling position of the circular index plate represent the swiveling position of the lever required in the basic threadpitches.**

**(4) The multiplying gear change handwheel(7) is used to connect the leadscrew or the feeding rod, and multiply the threadpitches or the feedrates.**

The locations of the handwheels are described as below. I ,II,III,IV: used connect the leadscrew for turning thread. A,B,C,D: used to connect the feeding rod for getting feed.

By matching above-mentioned handwheels' locations, various thread-pitches and feedrates can be batterned as shown in Table 4-2.

#### **(D) Special threadpitch turning**

The longitudinal motion of the leadscrew may be transmitted not via the variable gear train in feedbag but driven directly by the transposing gears between output shaft of headstock and input shaft of feedbox to enable the operator to cut threads of special pitch, the thread variety dial knob(5) has to be put on position “⊣” and the multiplying gear handwheel(7) has to be put on position “IV” .

**(E) Other operating functions are shown in Fig.4-1.**

• 云南机床厂

**Fig 4-1(A) The handwheel 11 is located on the left side of the apron**

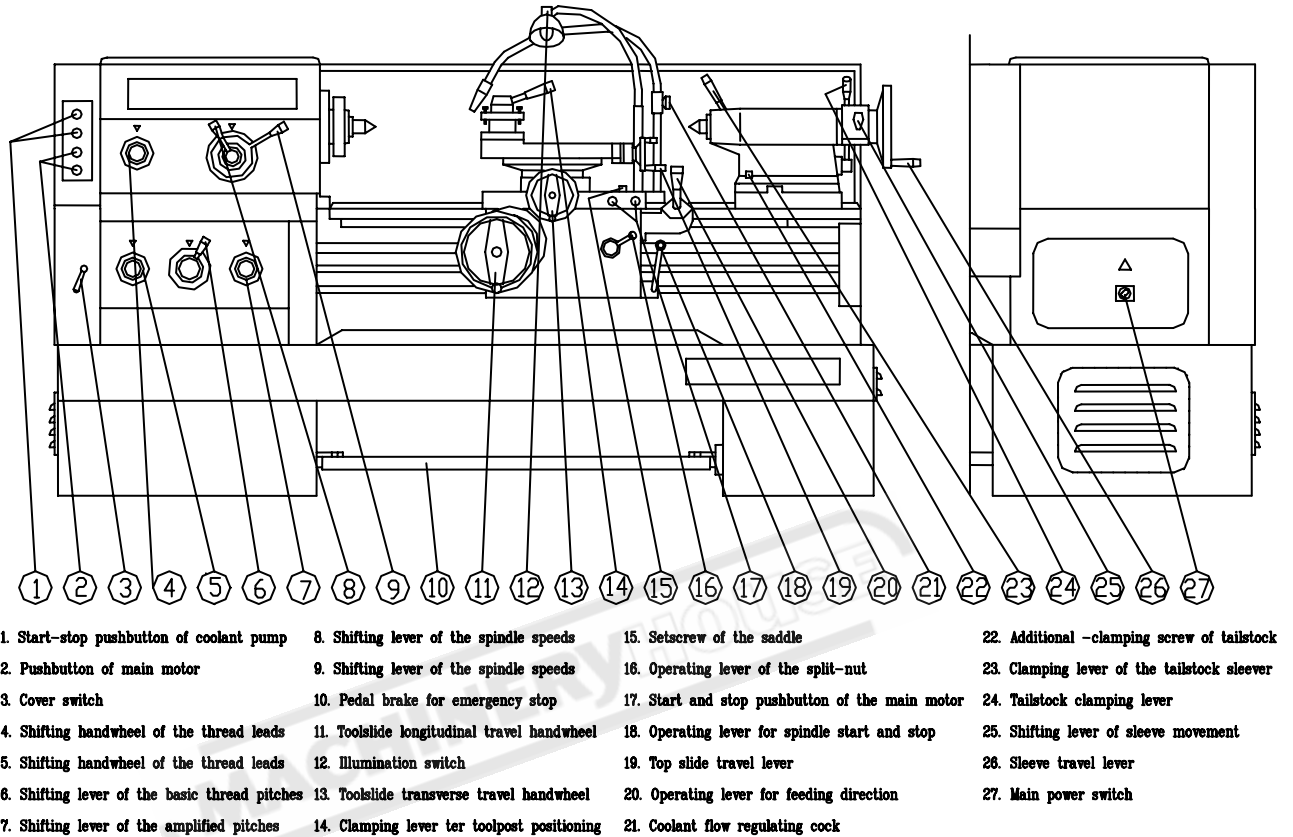



• 云南机床厂

**Fig 4-1(B) The handwheel 11 is located on the right side of the apron**

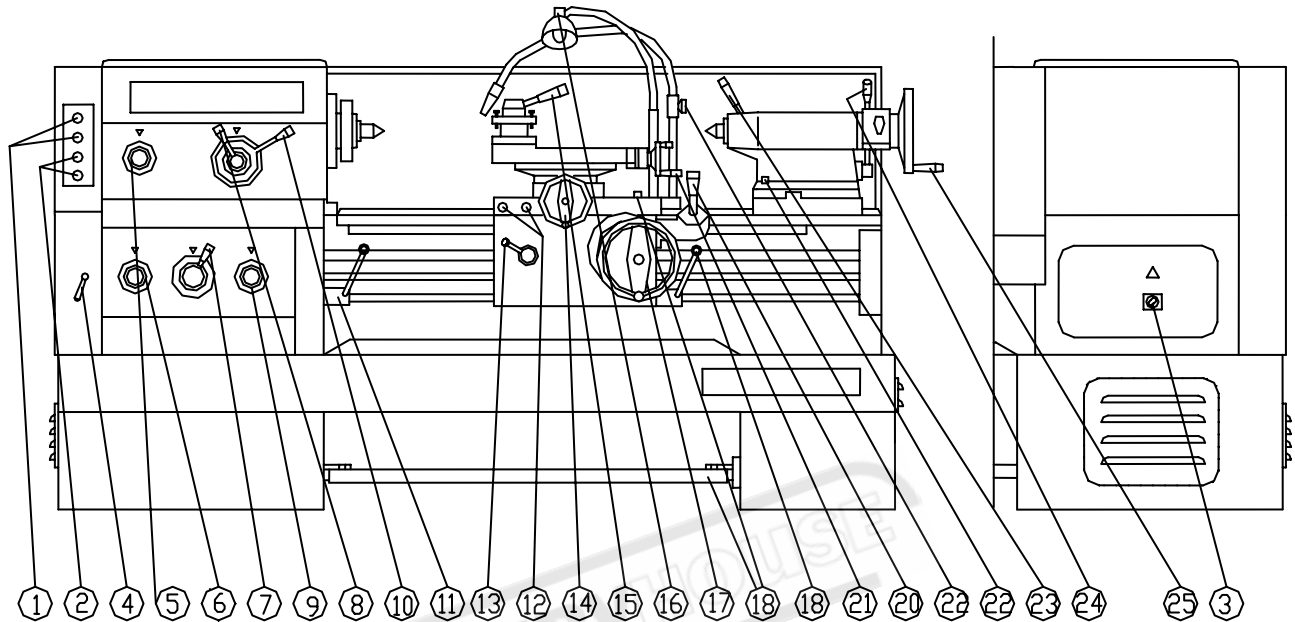

- |   |  |   |                                  |
|---|--|---|----------------------------------|
| 1. Publish-button control of coolant pump                       | 8. Main spindle speed change lever           | 15. Square turret turning clamping handle             | 21. Top slide trave lever        |
| 2. Publish-button control of main drive motor                   | 9. Feedbox multiplying gear change lever     | 16. Lamp switch                                       | 22. Coolant flow regulating lock |
| 3. Cover switch   | 10. Main spindle speed change lever          | 17. Saddle longitudinal travel hand wheel             | 23. Quill clamping handle        |
| 4. Pulley-guard clamping lever                                  | 11. Main spindle forward-brake-reverse lever | 18. Lock screw of saddle                              | 24. Tail stock clamping handle   |
| 5. Normal and amplified pitches, forward and reverse feed lever | 12. Push-button control of main motor        | 18. Spindle brake pedal                               | 25. Quill travel hand wheel      |
| 6. Feed and thread variety dial knob                            | 13. Split-nut closing and releasing lever    | 19. Main spindle forward-brake-revers lever           |                                  |
| 7. feedbox basic gear ratio change lever                        | 14. Cross slide traverse ball crank handle   | 20. Four-way power-feed lever with rapid-travel lever |                                  |

• 云南机床厂

Table 4-1

Serial No.	Spindle speeds			Calculating efficiency of transmission	Nominal capacity of motor										The weak link of transmission chain	Ratio of amplified pitches			
	Nominal value (Forward)	Calculating value			7.5 KW [10 HP]		11 KW [15 HP]		15KW [20 HP]		15KW [20 HP]		The weak link of transmission chain	Ratio of amplified pitches					
		(Forward)	(Forward)		(Reverse)	Max. output power of the mourn spindle													
	r/min	r/min			Output power		Torque		Output power		Torque		Output power				Torque		
	kw	HP	N.m	lbf.ft	kw	HP	N.m	lbf.ft	kw	HP	N.m	lbf.ft	kw	HP	N.m	lbf.ft			
1	6	6.2	6.3	0.77	0.95	1.2	1470	1085	0.95	1.2	1470	1085	0.95	1.2	1470	1085	16:1		
2	8	7.8	8.0		1.2	1.6			1.2	1.6			1.2	1.6					
3	10	9.8	10.0		1.5	2.0			1.5	2.0			1.5	2.0					
4	12	12.2	12.4		1.9	2.5			1.9	2.5			1.9	2.5					
5	16	15.2	15.5		2.3	3.1			2.3	3.1			2.3	3.1					
6	20	19.1	19.5		2.9	3.9			2.9	3.9			2.9	3.9					
7	25	23.9	24.4		3.7	4.9			3.7	4.9			3.7	4.9					
8	32	29.9	30.5		4.6	6.2			4.6	6.2			4.6	6.2					
9	56	56.1	57.2	0.81	6.1	8.14	1039	766	8.6	11.6	12.2	16.2	8.6	11.6	12.2	16.2	16:9		
10	71	70.6	72.0				825	609	1204	888			10.9	14.6					
11	90	88.2	90.0				661	488	964	711								1321	974
12	112	110.2	112.4				529	390	771	524								1057	780
13	140	136.9	139.6				426	314	621	458								851	628
14	180	172.2	175.6				338	249	494	364								677	499
15	215	215.2	219.5				270	199	395	291								542	400
16	270	269.0	274.4				217	160	316	233			12.2	16.2				433	319
17	224	224.5	229.0				260	192	379	280								519	383
18	280	282.2	287.8				206	152	301	222								413	305
19	335	352.8	359.9				165	122	241	178								330	243
20	450	440.9	449.7				132	97	193	142								264	195
21	560	547.7	558.7				106	78	155	114								213	157
22	710	688.6	702.4				85	63	123	91								169	125
23	900	860.7	877.9				68	50	99	73								135	100
24	1120	1075.9	1097.4				54	40	76	56								108	80

• 云南机床厂

Table 4-2 Metric lathe

mm/°						mm/°							
n	-t				m	t	n	t				m	t
A	B	C	D	D	B	A	B	C	D	D	B		
.063	.09	.18	.36	.71	2.86	.027	.038	.076	.152	.304	1.21	1	
.070	.10	.20	.40	.80	3.21	.030	.043	.085	.171	.341	1.37	2	
.073	.11	.22	.44	.88	3.33	.031	.044	.089	.177	.354	1.42	3	
.079	.11	.22	.45	.89	3.57	.033	.047	.095	.190	.379	1.52	4	
.081	.12	.24	.48	.96	3.67	.034	.049	.098	.195	.390	1.56	5	
.084	.12	.24	.48	.95	3.81	.036	.051	.101	.202	.405	1.62	6	
.087	.13	.26	.52	1.04	3.93	.037	.052	.104	.209	.417	1.67	7	
.13	.27	.54	1.07	1.68	4.29	.057	.114	.228	.455	.715	1.82	8	
.14	.29	.58	1.17	1.84	4.68	.062	.124	.248	.497	.780	1.97	9	
.15	.30	.60	1.21	1.89	4.82	.064	.128	.256	.512	.805	2.05	10	
.16	.31	.62	1.25	1.96	5.00	.066	.133	.266	.531	.834	2.12	11	
.16	.32	.64	1.29	2.02	5.14	.068	.137	.273	.546	.858	2.19	12	
.17	.34	.69	1.38	2.16	5.51	.073	.146	.293	.585	.919	2.34	13	
				1.43	2.24	5.71			.607	.954	2.43	14	
				1.61	2.52	6.43			.683	1.073	2.73	15	

○CYPML-93201/A

n	t				mπ				DP/1°π				n/1°																									
	I	II	III	IV	I	II	III	IV	I	II	III	IV	I	II	III	IV																						
	1	1	2	4	8	16	32	64	128	0.5	1	2	4	8	16	32	64																					
2		2.25	4.5	9	18	36	72	144			2.25	4.5	9	18	36	72																						
3																																						
4	1.25	2.5	5	10	20	40	80	160	1.25	2.5	5	10	20	40	80																							
5																																						
6																																						
7		2.75	5.5	11	22	44	88	176			2.75	5.5	11	22	44	88																						
8	1.5	3	6	12	24	48	96	192	0.75	1.5	3	6	12	24	48	96	48	24	12	6	3	1 1/2	3/4	3/8	24	12	6	3	1 1/2	3/4	3/8	3/16						
9																		44	22	11	5 1/2	3/4	11/16				22	11	5 1/2	3/4	11/16							
10																																						
11	1.75	3.5	7	14	28	56	112	224	1.75	3.5	7	14	28	56	112																							
12																		40	20	10	5	2 1/2	1 1/4	5/8	5/16	20	10	5	2 1/2	1 1/4	5/8	5/16						
13																																						
14																		36	18	9	4 1/2	1/4	1 1/8	9/16	18	9	4 1/2	1/4	1 1/8	9/16								
15																		32	16	8	4	2	1 1/2	1/4	16	8	4	2	1 1/2	1/4	1 1/8							



• 云南机床厂

Table 4-2(continued)The second kind of inch lathe

in/°										in/°										n/1°										t													
E					F					G					E					F					G					F					F								
A	A	B	C	D	D	B	A	A	B	C	D	D	B	A	A	B	C	D	H	G	E	I	II	III	IV	I	II	III	IV	I	II	III	IV	I	II	III	IV						
.0025	.0035	.0070	.0141	.0281	.112	.00054	.00076	.00152	.0030	.0061	.024	1																								1	2	4	8	16	32	64	128
.0028	.0040	.0079	.0158	.0316	.127	.00060	.00085	.00171	.0034	.0068	.027	2																								2.25	4.5	9	18	36	72	144	
.0029	.0041	.0082	.0164	.0328	.131	.00062	.00089	.00177	.0035	.0071	.028	3	19																							1.25	2.5	5	10	20	40	80	160
.0031	.0044	.0088	.0176	.0352	.141	.00067	.00095	.00190	.0038	.0076	.030	4																															
.0032	.0045	.0090	.0181	.0362	.145	.00069	.00098	.00195	.0039	.0078	.031	5																															
.0033	.0047	.0094	.0187	.0375	.150	.00071	.00101	.00202	.0040	.0081	.032	6																								2.75	5.5	11	22	44	88	176	
.0034	.0048	.0097	.0193	.0387	.155	.00074	.00104	.00209	.0042	.0083	.033	7																															
.0053	.0105	.0211	.0422	.084	.169	.00114	.00228	.0046	.0091	.0138	.036	8																								1.5	3	6	12	24	48	96	192
.0058	.0115	.023	.0460	.070	.184	.00124	.00248	.0050	.0099	.0151	.040	9																															
.0059	.0117	.0237	.0475	.072	.190	.00128	.00256	.0051	.0102	.0156	.041	10																															
.0062	.0123	.0246	.0492	.075	.197	.00133	.00266	.0053	.0106	.0161	.042	11																								1.75	3.5	7	14	28	56	112	224
.0063	.0127	.0253	.0506	.077	.202	.00137	.00273	.0055	.0109	.0166	.044	12																															
.0068	.0136	.0271	.0542	.082	.217	.00146	.00293	.0059	.0117	.0178	.047	13																															
				.0562	.085	.225			.0121	.0184	.049	14																															
									.0137	.0207	.055	15																															

○ CYPML-93201/C 0.633 .096 .253

mπ										DP/1°π										
F					F					E					E					
I	II	III	IV	I	II	III	IV	I	II	III	IV	I	II	III	IV	I	II	III	IV	
0.5	1	2	4	8	16	32	64	1												
		2.25	4.5	9	18	36	72	2												
		1.25	2.5	5	10	20	40	80	3											
									4	56	28	14	7	5 1/2	3 1/4	7/8	7/16			
									5											
									6											
									7											
									8	48	24	12	6	3	1 1/2	3/4	3/8			
0.75	1.5	3	6	12	24	48	96	9	44	22	11	5 1/2	3/4	11/16						
									10											
									11											
									12	40	20	10	5	2 1/2	1 1/4	5/8	5/10			
									13											
									14	36	18	9	4 1/2	1 1/4	1 1/8	7/16				
									15	32	16	8	4	2	1	1 1/2	1/4	1/8		

Table 4-2 (continued) The second kind of inch lathe

• 云南机床厂

**Table 4-2(continued) For Mixed Style lathe(the pitch of leading screw is 1/2" ,Other feed driving screws are in Metric)**

mm/φ							mm/φ							Z=81	
t				m			t				m			t	
A	B	C	D	D	B	A	A	B	C	D	D	B	A	Z=81	φ
.063	.09	.18	.36	.71	2.84	.013	.020	.038	.075	.152	.304	.608	.000	1	
.070	.10	.20	.40	.80	3.21	.014	.021	.042	.085	.170	.340	.680	.000	2	
.073	.11	.22	.44	.88	3.33	.015	.022	.044	.087	.174	.348	.696	.000	3	
.079	.11	.22	.45	.90	3.57	.016	.023	.047	.095	.190	.380	.760	.000	4	
.081	.12	.24	.48	.96	3.67	.017	.024	.048	.097	.194	.388	.776	.000	5	
.084	.12	.24	.48	.96	3.81	.018	.025	.050	.100	.200	.400	.800	.000	6	
.087	.13	.26	.52	1.04	3.93	.019	.026	.052	.105	.210	.420	.840	.000	7	
.13	.27	.54	1.07	1.63	4.29	.028	.057	.115	.227	.454	.908	.1816	.000	8	
.14	.29	.58	1.17	1.76	4.68	.031	.062	.125	.247	.494	.988	.1976	.000	9	
.15	.30	.60	1.21	1.83	4.82	.032	.064	.127	.254	.508	.102	1.02	.000	10	
.16	.32	.64	1.28	1.96	5.14	.033	.066	.132	.265	.530	.106	1.06	.000	11	
.17	.34	.69	1.38	2.08	5.51	.036	.073	.147	.292	.584	.117	1.17	.000	12	
														13	
										.302	.460	1.22	.000	14	
										.342	.517	1.37	.000	15	

○ CYPMI-93201/D

Z=82	t												mπ												DP/1"π												n/1"												Z=81
	I	II	III	IV	I	II	III	IV	I	II	III	IV	I	II	III	IV	I	II	III	IV	I	II	III	IV	I	II	III	IV	I	II	III	IV																	
1	1	2	4	8	16	32	64	128	0.5	1	2	4	8	16	32	64																																	
2		2.25	4.5	9	18	36	72	144		2.25	4.5	9	18	36	72																																		
3																																																	
4	1.25	2.5	5	10	20	40	80	160	1.25	2.5	5	10	20	40	80																																		
5																	56	28	14	7	3 1/2	3/4	7/8	7/16	28	14	7	3 1/2	3/4	7/8	7/16																		
6																									27																								
7		2.75	5.5	11	22	44	88	176		2.75	5.5	11	22	44	88																																		
8	1.5	3	6	12	24	48	96	192	0.75	1.5	3	6	12	24	48	96	48	24	12	6	3	1 1/2	3/4	3/8	24	12	6	3	1 1/2	3/4	3/8	5/16																	
9																	44	22	11	5 1/2	3/4	11/16			22	11	5 1/2	3/4	11/16																				
10																																																	
11	1.75	3.5	7	14	28	56	112	224	1.75	3.5	7	14	28	56	112																																		
12																	40	20	10	5	2 1/2	1/4	5/8	5/16	20	10	5	2 1/2	1/4	5/8	5/16																		
13																																																	
14																	36	18	9	4 1/2	1/4	11/8	9/16	18	9	4 1/2	1/4	11/8	9/16																				
15																	32	16	8	4	2	1 1/2	1/4	16	8	4	2	1 1/2	1/4	1/8																			

## ➤ V. Drive system

### A) Drive system

The drive system diagram is shown in Fig.5-1.

### B) Driving components

All driving components' parameters are listed on Table 5-1.

MACHINERYHOUSE

• 云南机床厂

Fig 5-1

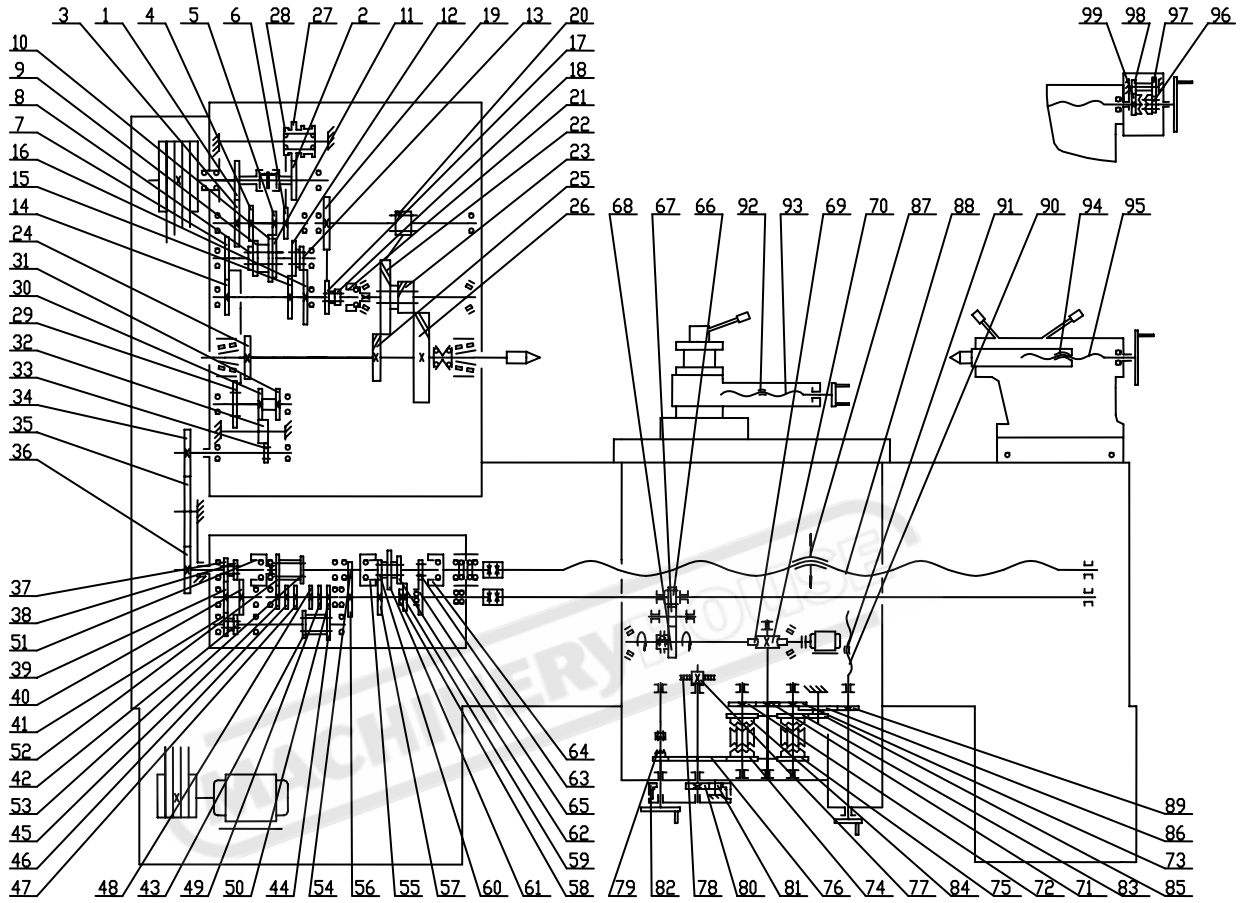



• 云南机床厂

Table 5-1

A. Part	Headstock																											
B. Drawing number	1	2	3	4	5	6	7	8	9	10	11	12	13	14	15	16	17	18	19	20	21	22	23	24	25	26	27	28
C. Number of teeth number of thread	56	56	40	36	28	32	48	32	36	44	40	36	20	32	45	61	20	17	60	20	17	60	24	72	60	90	48	39
D. Module, threadpitch	2.5	2.5	2.5	2.5	2.5	2.5	2.5	2.5	2.5	2.5	2.5	2.5	2.5	2.5	2.5	2.5	3	3	3	3	3	3	2.5	3	3	2.5	2.5	
E. Explanation of transposing gear supporter																												

A	Transposing gear supporter																														
B	29	30	31	32	33	34				35				36				37	38	39	40	41	42	43	44	45					
C	48	32	32	28	48	60	82	97	87	110	114	78	145	56	69	57	81	69	78	114	61	28	30	27	41	30	29	30	21	28	20
D	2.5	2.5	2.5	2.5	2.5	2	1.5	1.5	2	2	1.5	1.5	1.5	2	2	2	1.5	1.5	1.5	1.5	1.5	2.25	1.75	2.25	1.75	2.25	1.75	1.75	3	2	3
E						Metric machine tool inch machine tool	The second kind of inch lathe	Metric machine tool with D3600	Metric machine tool with D3630	Inch machine tool with D3600	Same with the left machine tool 181/30	Inch machine tool with D3630	Metric machine tool	Same with the left machine tool 181/30	Same with the left machine tool 181/30	Inch machine tool	Same with the left machine tool 181/30	Same with the left machine tool 181/30	Same with the left machine tool 181/30	Same with the left machine tool 181/30	The second kind of inch lathe										

A	Feed gear box																												Apron							
B	46	47	48	49	50	51	52	53	54	55	56	57	58	59	60	61	62	63	64	65	66	67	68	69	70	71	72	73	74	75	76					
C	18	21	36	32	33	30	21	28	14	22	42	33	15	24	22	40	32	21	21	42	36	32	56	2	26	32	36	36	45	45	87					
D	3	3	2	2	2	1.75	3	2	2.25	2.25	2.25	2.25	2.25	2.25	2.25	2.25	2.25	2	2	2	1.5	1.5	1.5	2.5	2.5	1.75	1.75	1.75	1.75	1.75	1.75					
E																																				

A	Apron														Toolslide						Tailstock						
B	77	78	79	80	81	82	83	84	85	86	87	88	89	90	91	92	93	94	95	96	97	98	99				
C	12	18	28	20	89	45	45	35	58	1	1	1	1	18	1	1	1	1	1	1	1	20	25	15	30		
D	2.5	2.5	1.75	1.5	1.5	1.5	1.75	1.75	1.75	1.75	12	12	1.75	5	5	5	5	5	5	5	5	1.5	1.5	1.5	1.5		
E		Rack									Metric machine tool inch machine tool	Metric machine tool inch machine tool		Metric machine tool inch machine tool	Metric machine tool inch machine tool	Metric machine tool inch machine tool	Metric machine tool inch machine tool	Metric machine tool inch machine tool	Metric machine tool inch machine tool	Metric machine tool inch machine tool							

---

## ✦ VI. Electrical System

### A) Electrical system

The machine can be provided optionally with electric equipments in AC frequency of 50Hz or 60Hz, in main voltage of 220V, 380V, 420V, or 440V, in motor power of 7.5KW, 11KW, or 15KW, and different braking mode of the main transmission according to various requirements of the customers, for which many electrical systems are available on request.

### B) The principle of electrical equipments.

The principle of electrical equipments is shown in Fig.6-1.

### C) Electrical wiring

The electrical wiring diagram is shown in Fig.6-2.

### D) Electrical installation

The electrical installation diagram is shown in Fig.6-3.

### E) Electrical equipments apparatus

The electrical equipments used in machine, their serial No. symbol main technical parameters and Quantity are given in Table 6-1.

### F) Precautions for safety protection

(1) Before switch-on, check whether the AC power frequency and voltage of the machine be confirmed with that on the dataplate. Only when the datum are the same can the machine be started running.

(2) Master fuse has not been provided with the electric system of the machine , which should be fixed on the lead-in line by the customer according to the electrical dataplate of the machine.

### Explain:

The principle of electrical system is shown in Fig 6-3 (page24). The electric wire diagram is shown in Fig6-4 (page25). The electric equipments diagram is shown in Fig6-5

• 云南机床厂

(page26) and the electric equipments list are shown in Fig6-6 (page27).

For adapting to the different power system of various countries and regions, the machine can be provided optionally with electrical equipments in AC frequency of 50HZ or 60HZ, in control voltage of 110v and in main voltage of 220V, 380V, 420V, or 440V, 600V, illuminator voltage of 24V, and in main motor power of 10HP, 15HP or 20HP. It is necessary for our endusers to make sure that the frequency and the voltage given or rating agree with the local power system.

Fuses are not provided with this machine. They can be mounted on the leading power line by our endusers according to the data on the rating plate.

Both power line and protective earth line should enter the machine through the cable gland on the left side of the front cabinet leg, since the wiring board is also placed to the left of its rear window. An enriching wire is to be let out from side hole and tightened on the screw connecting(PE) to the ground.

After closing the main switch QS, The pilot lamp HL1 and HL2 in green pushbuttons SB2 and SB3 of main motor M2 will light up, it shows that the circuit is being connected and that the main motor is being started. By pressing down the start button of main motor, the pilot lamps will go out, it shows the completed and the main motor is being started. By pressing down the red pushbutton SB4 which serve to stop the main motor.

After starting the main motor, the pilot lamp HL3 in green start button SB5 of coolant pump will light up, pressing down this button may start the coolant pump. Once the main motor is stopped, the coolant pump will stop automatically.

A protective switch SQ is built in the belt cover, when opening the cover, the main motor can not be started. An urgent stop pushbutton (SB1) can cut off electric circuitry and can stop the machine. After removing trouble, turn this button in the direction the black arrow indicate to 30°, then the machine can be restarted.

After the electric power is being connected, the rapid travel motor M4 is controlled by black pushbutton SB7 and the work lamp EL1 is controlled by switch K on lamp socked.

A hanger hole for the naked lock is also provided with the power switch of the machine. Various naked locks can be equipped at the customer' s choice.

Special tools for opening the electrical equipment cabinet are available in accessory box.

• 云南机床厂

### The Diagram of Electric Circuit

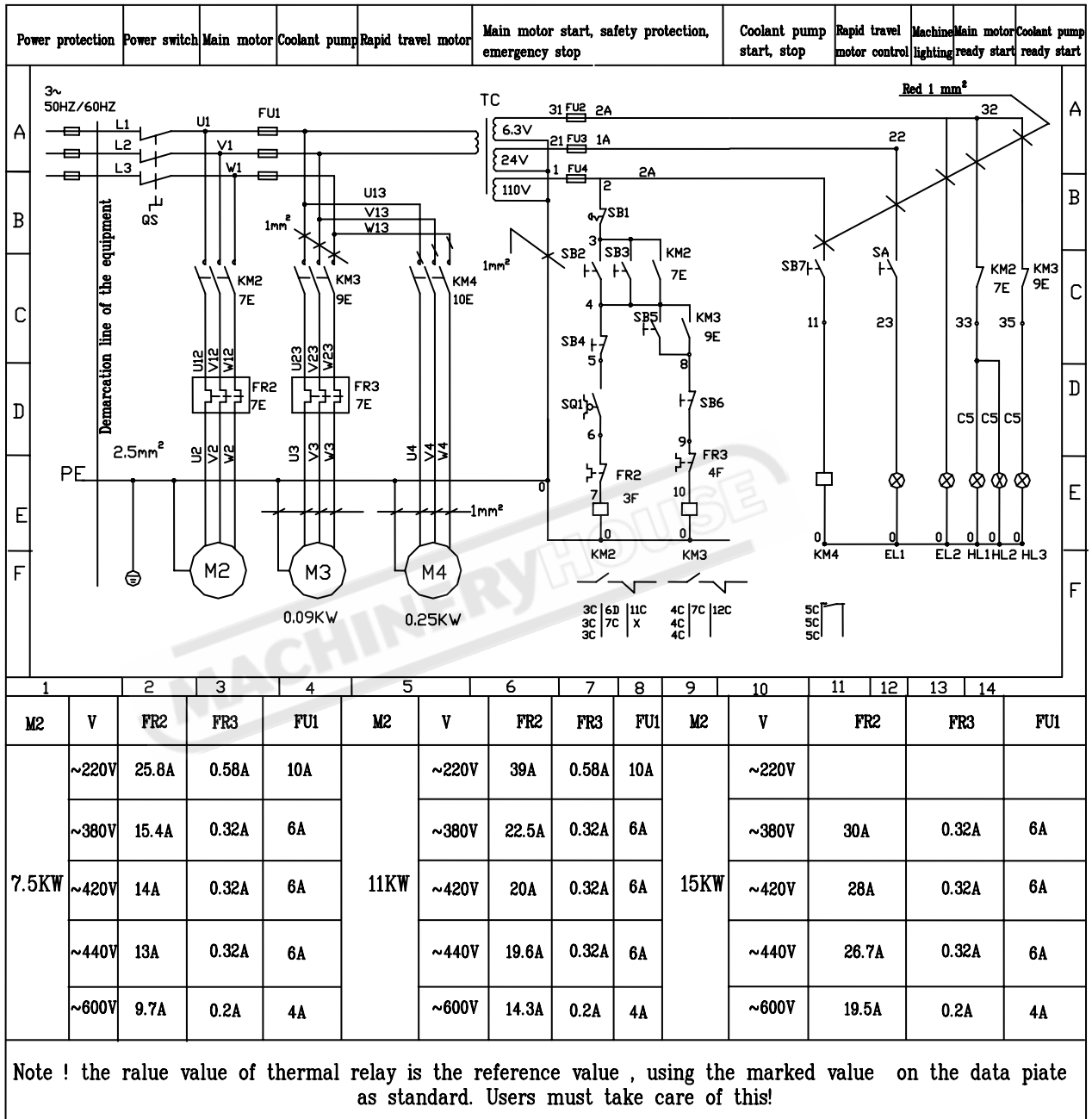

• 云南机床厂

Wiring diagram(图6)

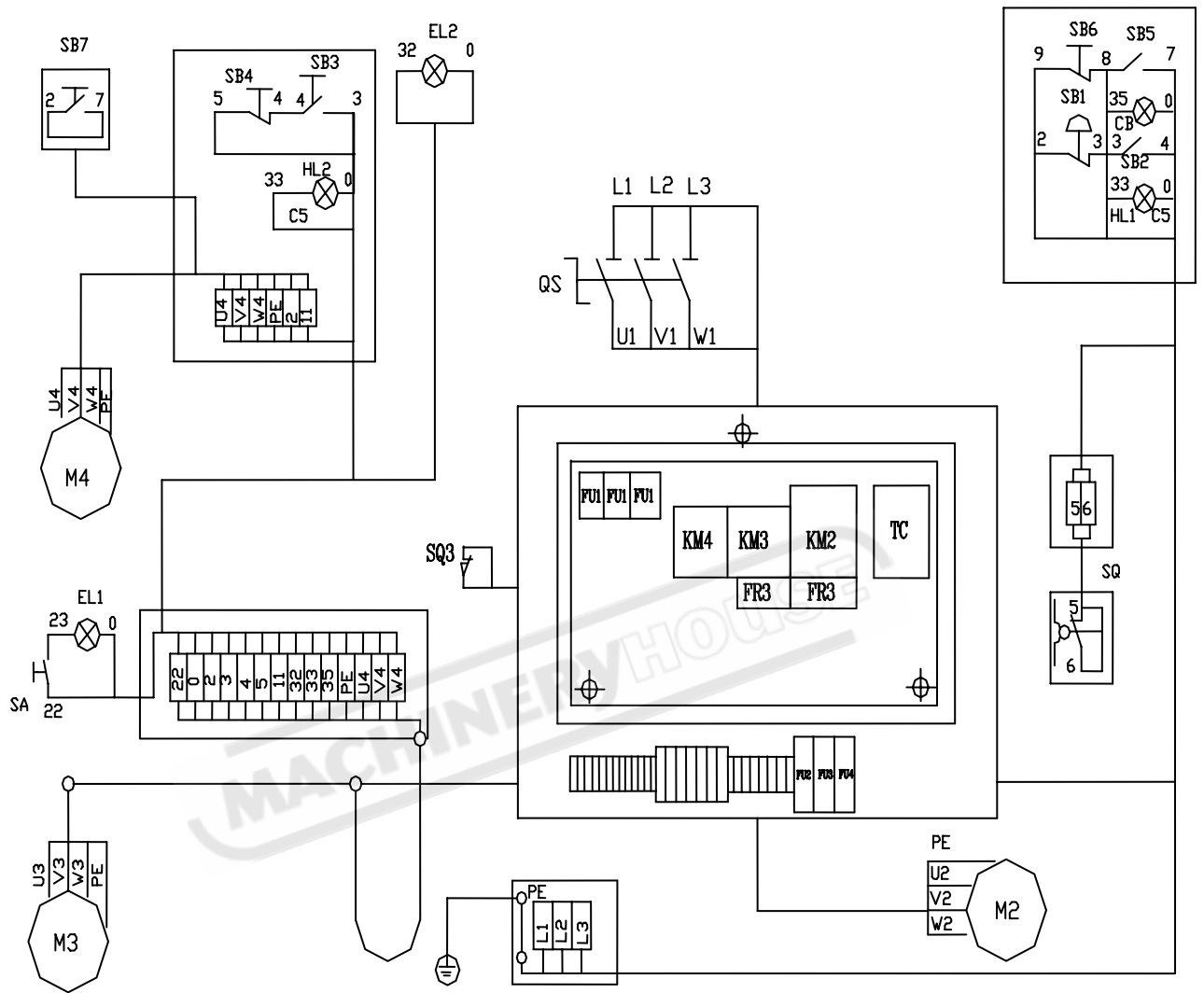

• 云南机床厂

**Power 3~50Hz(60HZ)**

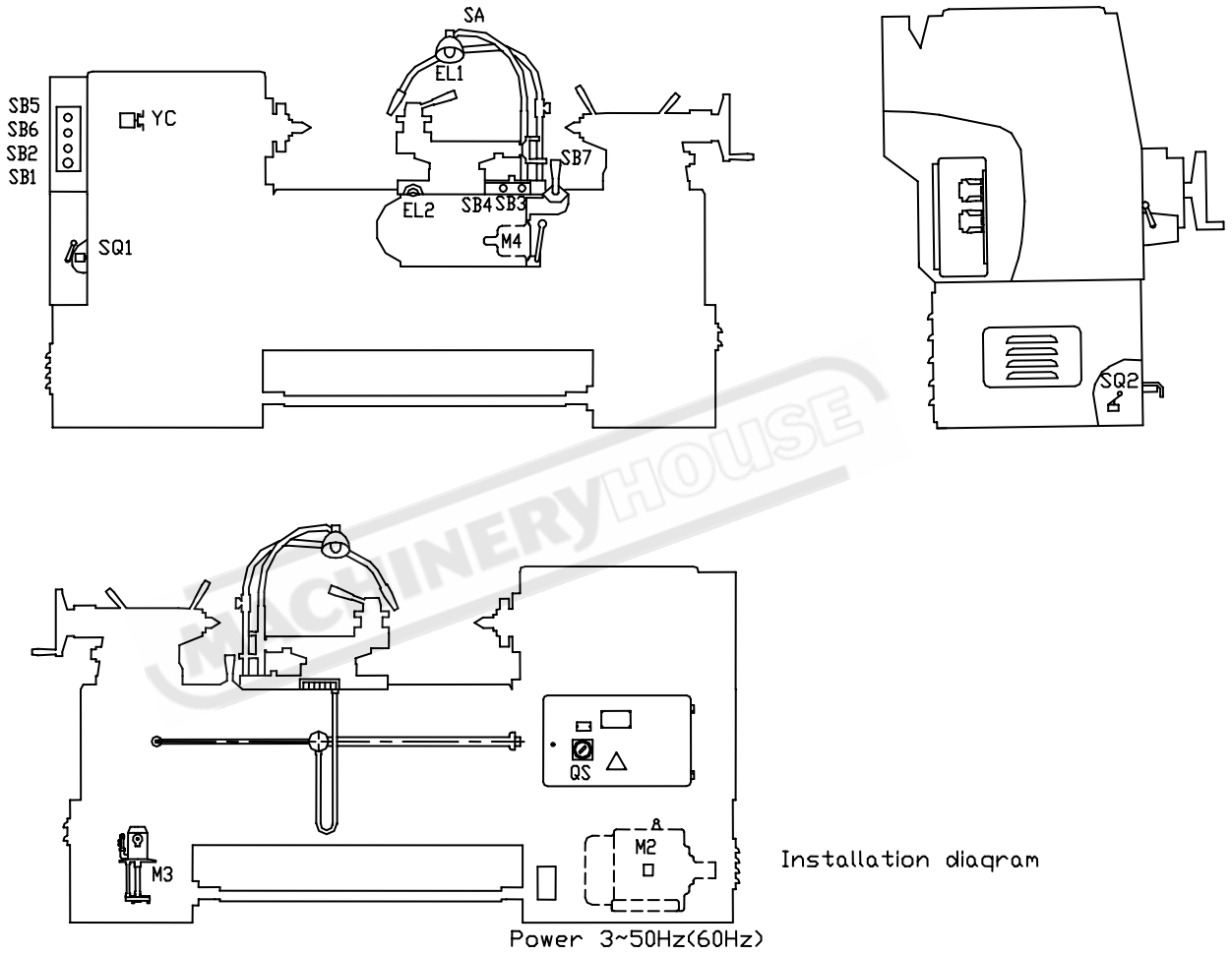

• 云南机床厂

Table 6 list of electric equipments

No. of electric equipments	No. of electric diagram	Name and applications	Technical parameter	Quantity	Remarks (Reference model)
SB1	6A	Pushbutton Emergence stop Self-locking	Uc: 380V~Ith=5A φ 35, red 1<b>	1	LAY3-0112
SB2	6C	Mushroom	φ 28 green,	1	LA19-11D
SB3	6C	Main motor	I<a>+1<b>	1	LA19-11D
SB4	6C	start	lamp : 6.3V,	1	LA19-11
SB5	7C	Main motor start	1W, BA9S φ 28 red, 1 <a>+<b>	1	LA19-11D
SB6	7D	Main motor	φ 28	1	LA19-11
SB7	8C	stop Cooling pump start  Cooling pump stop Rapid travel motor start	green, 1<a>+1<b> lamp:6.3V, 1W, BA9S φ 28 red, 1<a>+<b> Uc: 380V~Ith=5A Black, 1<a>+<b>	1  1	LAY10
SQ	6D	Limit switch	Uc: 380V~Ith=5A 1<a>+<b>	1	LX19K
EL1	9F	Work lamp	24V~, 40W Lamp	1	JC11-1
EL2	10F	Pilot lamp	holder E27 6.3V~, 1W, colorless, BA9S	1	XD-0
FU1	3A	Fuse	Fuse link: 6A used for power of	3	AM3

• 云南机床厂

<b>FU2</b>	<b>6A</b>	<b>Fuse</b>	<b>(660V, 380V, 420V, 440V)</b>	<b>1</b>	<b>gF1</b>
<b>FU3</b>	<b>6A</b>	<b>Fuse</b>	<b>10A used for power of 220V</b>	<b>1</b>	<b>gF1</b>
<b>FU4</b>	<b>6A</b>	<b>Fuse</b>	<b>fuse link: 1A fuse link: 2A fuse link: 2A</b>	<b>1</b>	<b>gF1</b>
<b>TC</b>	<b>6A</b>	<b>Control transformer</b>	<b>Primary:660V, 220V, 380V 420V, 440V 50Hz(60Hz) Secondary: 110V, (110VA)24V,(50VA) 6.3V(10VA)</b>	<b>1</b>	<b>JBK4-160 Depending on the power voltage of the principle of electrical diagram reference</b>
<b>QS</b>	<b>2A</b>	<b>Power switch</b>	<b>Three-Phase: Ue: 550V~Ie:25A</b>	<b>1</b>	<b>HY12-25-SG Applied to: power: 380V~420V~440V~ 600V main motor: 7.5KW power: 420V~440V~600V main motor 11KW  HY-12-40-SG Applied to: Power: 220V Main motor: 7.5KW Power: 220V~380V</b>



• 云南机床厂

					<b>Main motor:</b> <b>11KW</b> <b>Power:</b> <b>380V~420V~440V~</b> <b>600V</b> <b>Main motor:</b> <b>15KW</b>
<b>M2</b>	<b>3F</b>	<b>Three phase squirrel cage</b>  <b>Let mounting type</b>	<b>7.5KW ,1500r.p.m</b> <b>Insulation in B class</b> <b>50Hz(60Hz)</b>	<b>1</b>	<b>Y132M-4</b> <b>Corresponding power:</b> <b>220VV~380V~420V~440V~600V</b>
<b>M3</b>	<b>4F</b>	<b>Three phase motor pump</b>	<b>0.09Kw, 1500r.p.m</b> <b>Insulation in B class</b> <b>50Hz(60Hz)</b>	<b>1</b>	<b>40B-25</b> <b>Corresponding power:</b> <b>220VV~380V~420V~440V~600V</b>
<b>M4</b>	<b>5F</b>	<b>Three phase squirrelcage motor</b> <b>Flange mounting type</b>	<b>0. 25Kw, 1500r.p.m</b> <b>Insulation in B class</b> <b>1. 50Hz(60Hz)</b>	<b>1</b>	<b>2AoS5634</b> <b>Corresponding power</b> <b>220VV~380V~420V~440V~600V</b>

• 云南机床厂

KM2	6F	Contactor	<p><b>Triple-pole:</b>  <b>Uc660V~Ic: 22A/AC3</b>  <b>Coil:110V~50Hz(60Hz</b>  <b>)</b>  <b>Auxiliary contact</b>  <b>head</b>  <b>Uc:110V~, Ith=5A</b></p>	1	<p><b>3TB4317</b>  <b>Suitable for Power:</b>  <b>380V~420V~440V~</b>  <b>600V</b>  <b>Main motor:</b>  <b>7.5Kw</b>  <b>For power:</b>  <b>440V~600V</b>  <b>Main motor: 11Kw</b></p>
			<p><b>Triple-pole:</b>  <b>Uc660V~Ic: 32A/AC3</b>  <b>Coil:110V~50Hz(60Hz</b>  <b>)</b>  <b>Auxiliary contact</b>  <b>head</b>  <b>Uc:110V~, Ith=5A</b></p>		<p><b>3TB4317</b>  <b>Suitable for Power:</b>  <b>380V~420V</b>  <b>Main motor: 11Kw</b>  <b>For power: 220V</b>  <b>Main motor: 11Kw</b></p>
			<p><b>Triple-pole:</b>  <b>Uc660V~Ic: 45A/AC3</b>  <b>Coil:110V~50Hz(60Hz</b>  <b>)</b>  <b>Auxiliary contact</b>  <b>head</b>  <b>Uc:110V~, Ith=5A</b></p>		<p><b>3TB4617</b>  <b>Suitable for Power:</b>  <b>440V~220V</b>  <b>Main motor: 11Kw</b>  <b>For power:</b>  <b>380V~420V~440V~</b>  <b>600V</b>  <b>Main motor: 15Kw</b></p>
KM3	7F	Contactor relay	<p><b>Triple-pole:</b>  <b>Uc660V~Ic: 9A/AC3</b>  <b>Coil:110V~50Hz(60Hz</b>  <b>)</b>  <b>Auxiliary contact</b>  <b>head</b>  <b>Uc:110V~, Ith=5A</b></p>	2	3TB4012
KM4	8F				

• 云南机床厂

FR2	3D	Overcurrent relay	Current range/rate value 14-22A/15.4A	1	3UA52 Power: 380V Main motor: 7.5Kw
			20-32A/25.80A		3UA54 Power: 380V Main motor: 7.5Kw
			10-16A/14A		3UA52 Power: 420V Main motor: 7.5Kw
			10-16A/13A		3UA54 Power: 440V Main motor: 7.5Kw
			28-45A/39A		3UA59 Power: 220V Main motor: 11Kw
			12.5-20A/14.5A		3UA52 Power: 660V Main motor: 11Kw
			20-32A/22.5A		3UA54 Power: 380V Main motor: 11Kw
			9-12.5A/9.8A		1
			14A-22A/20A	3UA52 Power: 420V Main motor: 11Kw	

• 云南机床厂

			<b>14A-22A/19.6A</b>		<b>3UA52 Power: 440V Main motor: 11Kw</b>
<b>FR3</b>	<b>4D</b>	<b>Ovtrcurrent relay</b>	<b>Current range/rated value</b>	<b>1</b>	<b>3UA50 power: 380V~420V~440V</b>
			<b>0.4-0.63A/0.58</b>		<b>Power: 220V</b>
			<b>0.25-0.35A/0.32A</b>		<b>Power: 600V</b>
			<b>0.16-0.25A/0.2A</b>		

MACHINERYHOUSE

• 云南机床厂

## VII. Lubricating system

All lubricating points and actuating points of the machine are shown in Fig7-1.

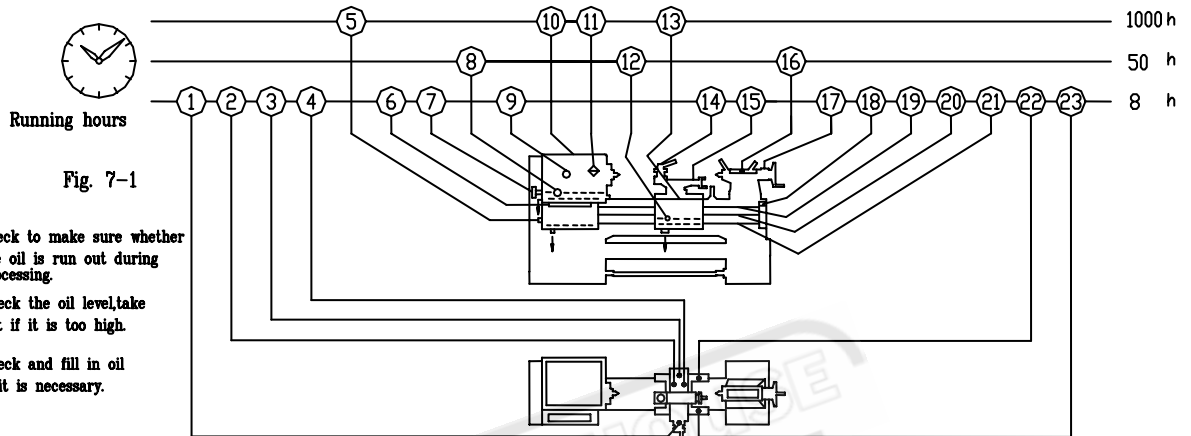

Fig. 7-1

- \*1. Check to make sure whether the oil is run out during processing.
- \*2. Check the oil level, take out if it is too high.
- \*3. Check and fill in oil if it is necessary.

Accessories	Lower slide				Feed gear box		Transposing gear support	Headstock box				Apron		Top slide		Tailstock		Bracket, lead screw, feeding rod, operating rod			Saddle		
Acting-point serial No.	1	2	3	4	5	6	7	8	9	10	11	12	13	14	15	16	17	18	19	20	21	22	23
Time Symbol																							
Fill in oil h	8	8	8	8	8	8	8		8					8	8			8	8	8	8	8	8
* 1 h									8														
* 2 h									50			50				50							
* 3 h					1000																		
Clean and replacement h											1000												
Replace oil h										1000		1000											
Filling amount L	0.002				0.01	0.001		6.8				0.95	0.002		0.002			0.002			0.002		
Name of lubricant	Lubrication oil N32 V = 28.8-35.2mm <sup>2</sup> /sec						Normal calcium base grease	Lubrication oil				N32 V = 28.8-35.2mm <sup>2</sup> /sec											

Fig 7-1

### VIII. Cooling system

The storage of the coolant its delivery and regulation are given in Fig 8-1.

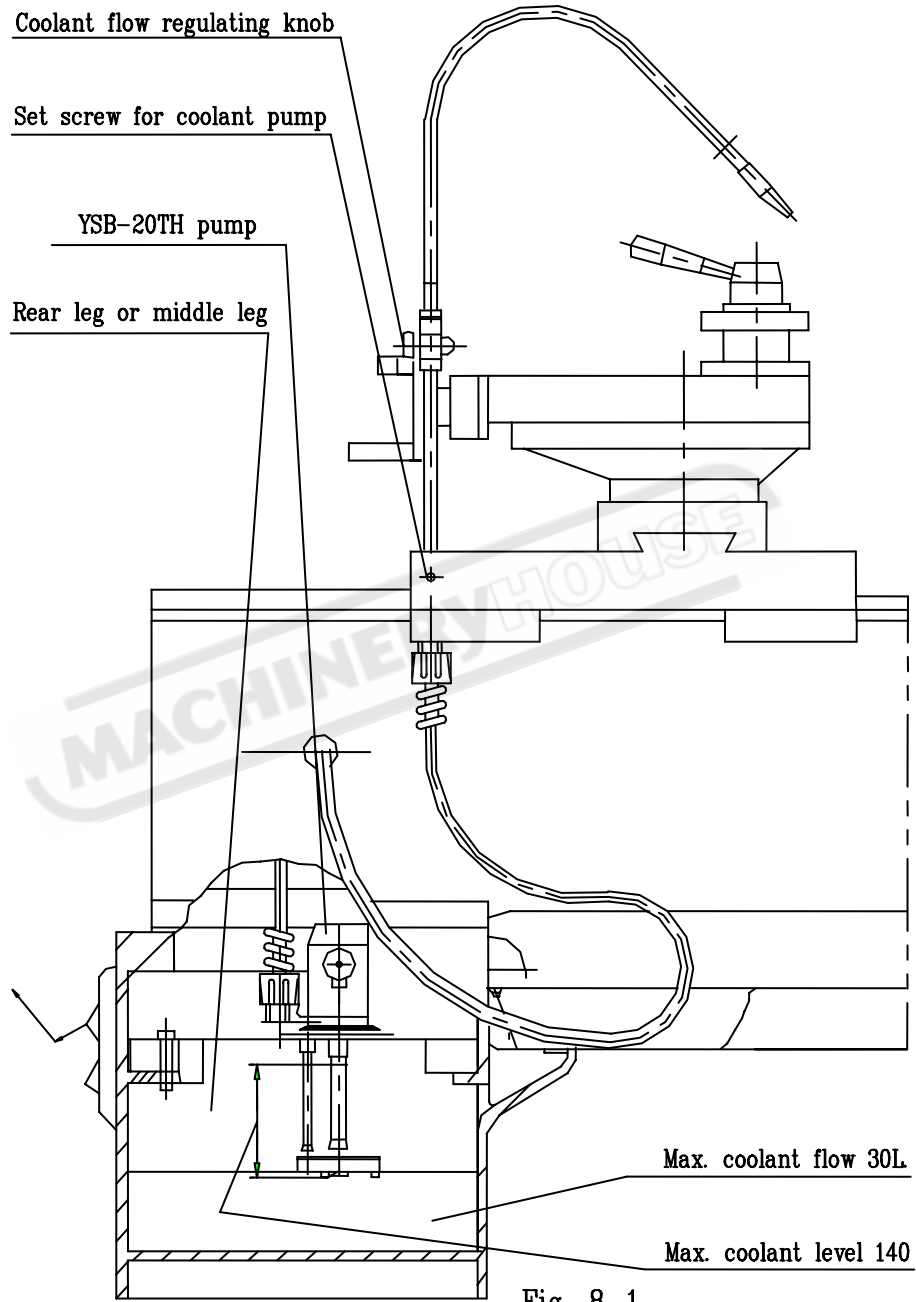

Fig. 8-1

---

## IX. Construction and adjustments

### A) Adjustments of the transposing gear for other threadpitch cutting.

The machine has been setup and well adjusted before delivery from the factory according to the obtainable feedrates and normal threadpitches shown on the Fig.9-1 when other threadpitches or threads need to be turned. The matching pair of transposing gears is specified in Table 9-1, and installation adjustment and fixing can be carried out according to the location specified in Table 9-1.

### B) Adjustments of tailstock in transverse

The conformance between headstock center and tailstock center has been setup before delivery from the factory. Release the locking lever of the tailstock when needles transverse motion of the tailstock, and reset as shown in Fig.9-2.

C) Installation and adjustment of the D-type spindle chuck. When D-type spindle head is installed, the reference line on the chuck must be aligned with the reference line of the spindle head. (Fig.9-3), then successively tighten the six locking cams in clockwise direction or conversely removing the chuck.

Note: After tightening the locking cans, the marline on the can should be located between the two limit symbols, otherwise readjust the length of pulling rod.

D) The assembly or disassembly of the other components is shown in Fig.9-4.

• 云南机床厂

Fig 9-1 Each module and teeth of A .B .C are available according to the following table

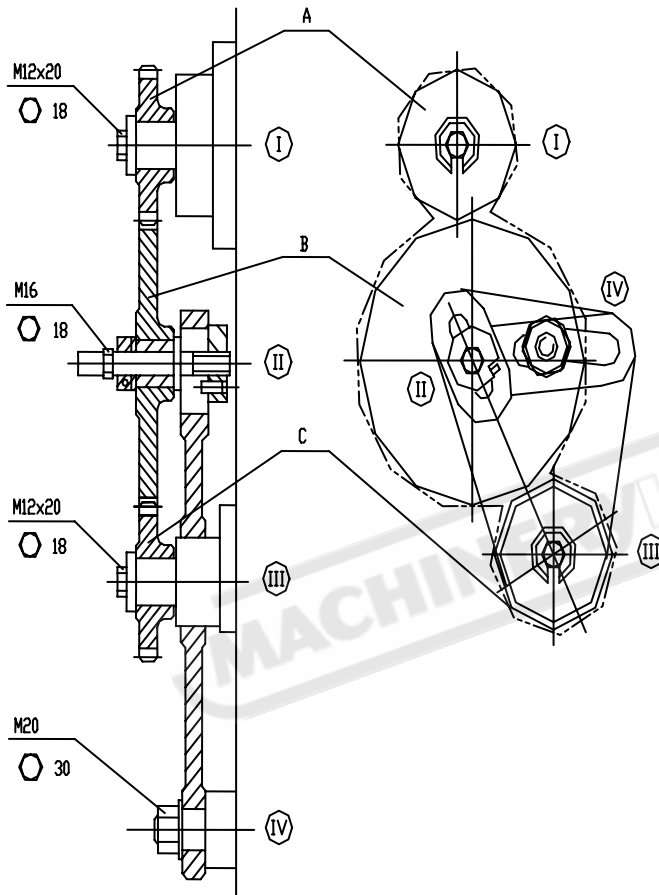

Metric		Db < 500mm [20"]		Lathe		n=2	
Threadpitch	Various threadpitches			11 1/2 t/in	19 t/in		
$\frac{A}{B} \times \frac{B}{C}$	$\frac{60}{87} \times \frac{87}{56}$			$\frac{60}{87} \times \frac{87}{69}$	$\frac{60}{87} \times \frac{87}{57}$		

Metric		Db > 630mm [25"]		Lathe		n=2	
Threadpitch	Various threadpitches			11 1/2 t/in	19 t/in		
$\frac{A}{B} \times \frac{B}{C}$	$\frac{60}{110} \times \frac{110}{56}$			$\frac{60}{110} \times \frac{110}{69}$	$\frac{60}{110} \times \frac{110}{57}$		

Inch		Db < 20' [500mm]		Lathe		n=1.5	
Threadpitch	Various threadpitches			11 1/2 t/in	13 t/in	19 t/in	
$\frac{A}{B} \times \frac{B}{C}$	$\frac{82}{114} \times \frac{114}{81}$			$\frac{82}{114} \times \frac{114}{69}$	$\frac{82}{114} \times \frac{114}{78}$	$\frac{82}{78} \times \frac{114}{114}$	

Inch		Db > 25' [630mm]		Lathe		n=1.5	
Threadpitch	Various threadpitches			11 1/2 t/in	13 t/in	19 t/in	
$\frac{A}{B} \times \frac{B}{C}$	$\frac{82}{145} \times \frac{145}{81}$			$\frac{82}{145} \times \frac{145}{69}$	$\frac{82}{145} \times \frac{145}{78}$	$\frac{82}{145} \times \frac{145}{114}$	

The second Inch system Db < 20' [500mm] Lathe			n=1.5	
Threadpitch	Inch, metric threadpitches	Diametral module threadpitch		
$\frac{A}{B} \times \frac{B}{C}$	$\frac{82}{114} \times \frac{114}{81}$	$\frac{97}{114} \times \frac{114}{61}$		

The second Inch system Db > 25' [630mm] Lathe			n=1.5	
Threadpitch	Inch, metric threadpitches	Diametral module threadpitch		
$\frac{A}{B} \times \frac{B}{C}$	$\frac{82}{145} \times \frac{145}{81}$	$\frac{97}{145} \times \frac{145}{61}$		



Fig 9-2

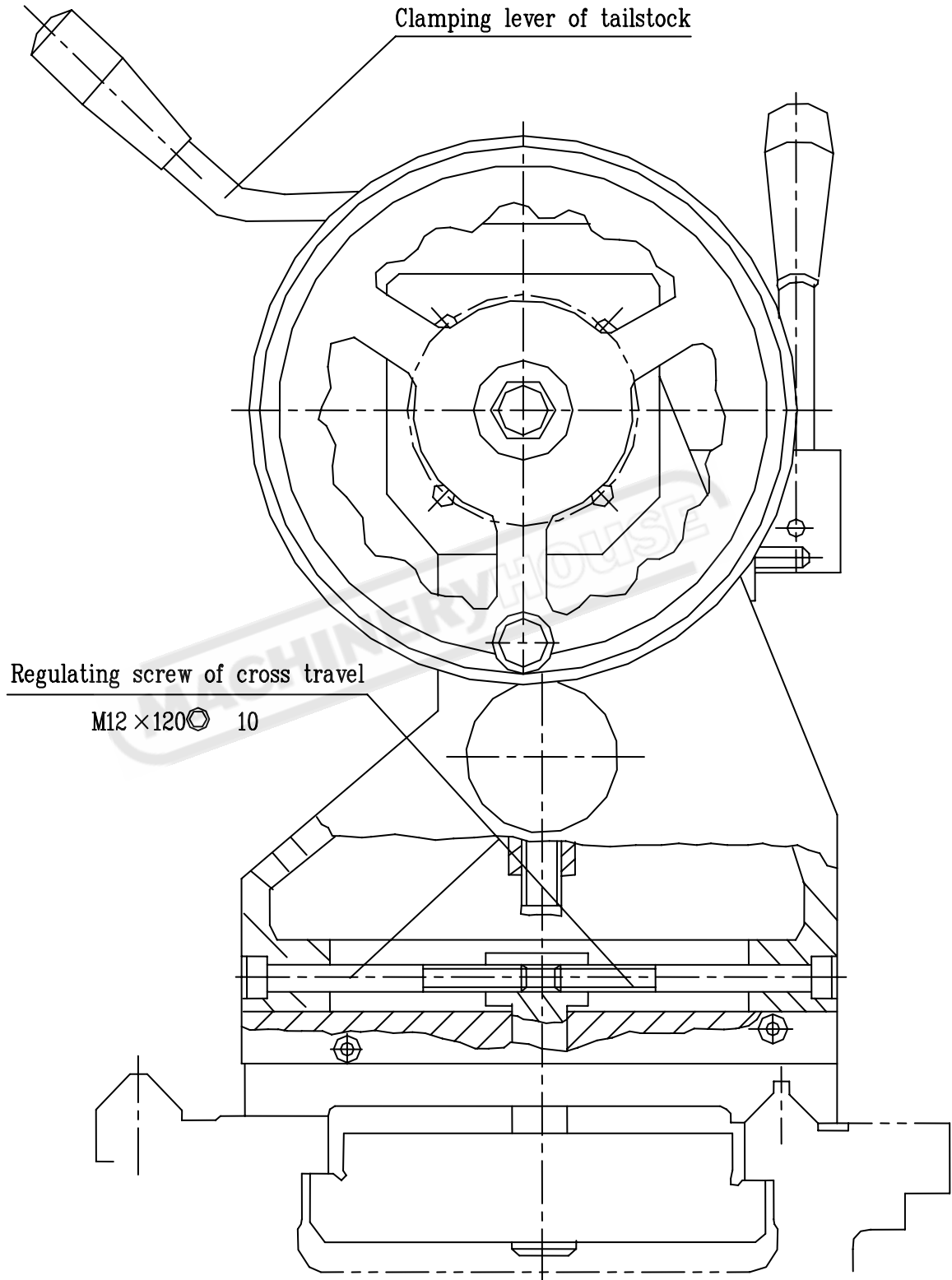
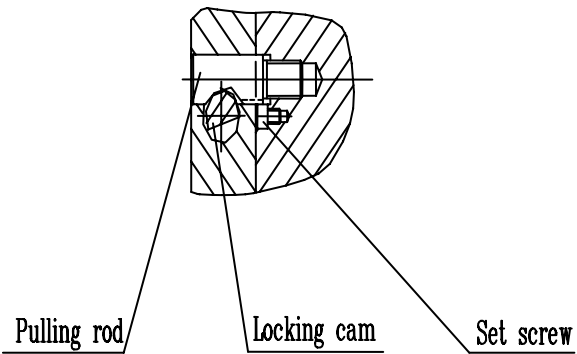
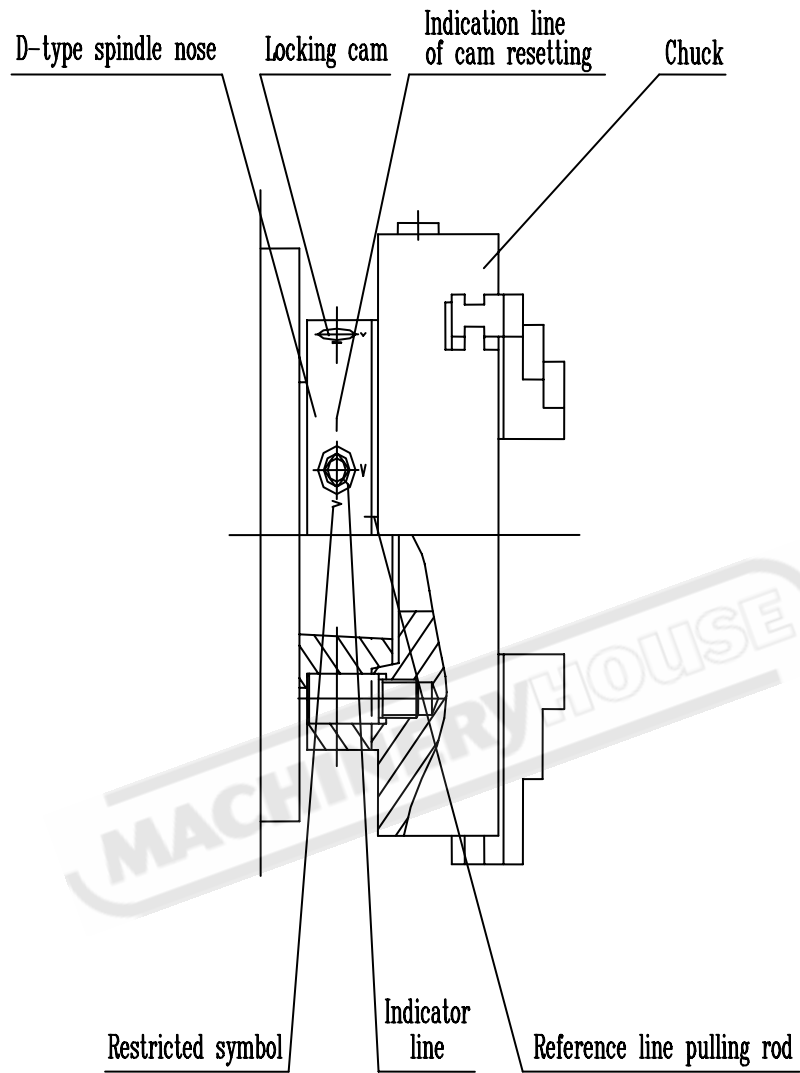
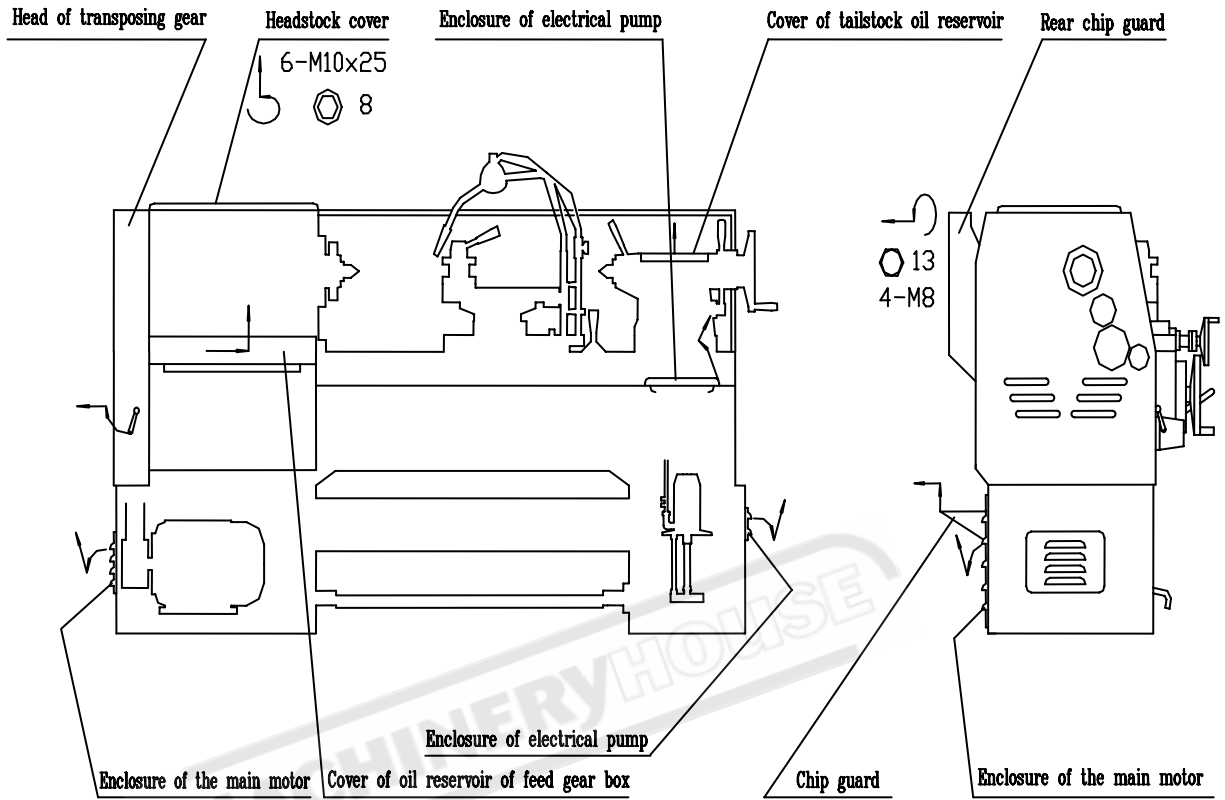

Fig 9-3



• 云南机床厂

Fig 9-4



---

## X. Maintenance and service

### A. Lubricating

For the sake of ensuring proper operation of the machine and decrease the parts' worn-out, please pay appropriate attention to the following suggestions:

- (1) All lubrication points should be oiled according to the lubrication diagram before any cutting is attempted. The lubricants must be of a good quality and clean.
- (2) As the initial wearing value of new machineparts is greater it is recommended that the first and second oil-change the headstock and the apron should be carried out after about 160 hours and 320 hours respectively, thus the impurities may be removed in due item. Flush the inner parts in the box thoroughly with new kerosene after removing the impurities.
- (3) The scrapping board of the guideway must be clean, replacement will be made in castoff worn-out parts being found.

### B. Operation

For the sake of maintaining the original accuracy for precision performance in long periods, pay close attention to the following suggestions during operating.

- (1) After the main motor is started, check the working condition of the oil pump first through the oil window of headstock. Only when oil appears in the window, the spindle may be started.
- (2) Check whether the gear shifting levers , handwheels be put in their correct catch position, thus ensuring smooth motion of gear box.
- (3) Changing the speed of main spindle can only be done when the spindle stops rotating. In any case the gear shifting levers should not be actuated when the spinalis is in rapid revolution.

Changing the feedrates can be done in low-speed rotating or in stopping condition of main spindle.

- (4) If the brake in headstock is out of order, it should be adjusted or repaired in time. Don't use the reverse friction clutch instead of the brake for stopping.
- (5) When actuating the main spindle forward-stop-reversing lever in operation, the lever must be pulled or pressed to the proper position. It is not allowed to do speed-down

• 云南机床厂

cutting when the lever is not yet brought into position.

(6) When the taper bore in center sleeve of tailstock is used to hold the tool for cutting, tool of M. T. No.5 taper shank with tang should be selected, and the tang have to be plugged levelly close against the stop dog in the sleeve so as to prevent the tool from rotating in operation and injuring the finished surface of taper bore.

(7) The long leadscrew is used only for thread cutting. For maintaining it' s accuracy and prolong the service life it is not allowed to use the leadscrew for longitudinal feeding instead of feed rod.

(8) The apron is directly by the leadscrew and nut in thread cutting and the overload clutch in the apron is then no more a safeguard in this operating, for the reason of avoiding damages of the machine parts, the cutting depth in thread cutting should be attentively considered so as to keep the feeding force pox not exceed 3400N.

(9) When the steady rest and the follow rest are used in operation, the supporting surface of workpiece should be oiled lubricants.

(10) The main power supply should be cut off when the operator leaves away from the machine or in case of loading or unloading the workpiece.

### C. Trouble checklists

No.	Trouble	Probable Cause	Corrections
1	Spindle doesn' t reach the torsional limitation	1. Main drive pulley is loosed 2. Main drive clutch is loosed	1. Tighten the motor pulley 2. Adjust the clutch
2	Too much force is imposed on the spindle start operating lever or operation of the lever is not to its proper position	1. The main drive clutch is set too tight 2. Breaking hand in head-stock is too tight	1. Adjust the clutch 2. Adjust the braking band
3	Long time stopping of the main spindle	The braking band in head-stock is loosed	Adjust the braking band

• 云南机床厂

No.	Trouble	Probable Cause	Corrections
4	Emergency stop of the pedal control, long time stop of the spindle	The braking band of the main motor in front leg is loosed	Adjust the braking band
5	The radial run-out of the spindle head exceeds the limit	The axial clearance between front bearing and rear hearing of the spindle is too big	Adjust the front and rear bearings
6	Axial slip of the spindle is over the limitation	Too big the clearance in the front rake of thrust bearing of the spindle	Adjust the front rake of the thrust bearing
7	Wobbling of the tachometer	The operating chain in head-stock is loosed	Tighten the operating chain
8	Clamping lever of the tail-stock is not clamped to its proper position and not clamped	The clamping-down screw cap is adjusted too tight	Adjust the clamping-down screw cap correctly
9	Clamping lever of the tail-stock is not clamped to is proper position and not clamped	The clamping-down screw cap is adjusted too loose	Adjust the clamping-down screw cap correctly
10	Longitudinal motion of tail-stock is over pushed	Malfunction of tail-stock pending device	Adjust the pending bearing built in the bottom of tail-stock base plate
11	Over limits of the repeated positioning accuracy of toolslide	<ol style="list-style-type: none"> <li>1. The initial positioning ball of the toolslide is too tight</li> <li>2. The positioning surface of toolslide is dirty</li> </ol>	<ol style="list-style-type: none"> <li>1. Adjust the thread of ball spring</li> <li>2. Clean the tool bracket</li> </ol>

• 云南机床厂

No	Trouble	Probable Cause	Corrections
12	Over station of tool exchange	<ol style="list-style-type: none"> <li>1. Too much force exerted</li> <li>2. The ball spring of toolslide is loosed</li> </ol>	<ol style="list-style-type: none"> <li>1. Reduce exerting force</li> <li>2. Adjust the thread of ball spring</li> </ol>
13	The reverse clearance of toolslide in transverse direction is too big	<ol style="list-style-type: none"> <li>1. The split-nut of lead-screw is loosed</li> <li>2. The axial fixed nut of leadscrew is loosed</li> </ol>	<ol style="list-style-type: none"> <li>1. Adjust the clearance of lead-screw nut in transverse</li> <li>2. Adjust the axial fixed nut</li> </ol>
14	Reverse clearance of upper toolslide motion is too big	<ol style="list-style-type: none"> <li>1. The split-nut of the lead-screw is loosed</li> <li>2. The axial fixed nut of lead-screw is loosed</li> </ol>	<ol style="list-style-type: none"> <li>1. Adjust the clearance of lead-screw nut in transverse</li> <li>2. Adjust the axial fixed nut</li> </ol>
15	The movement of dovetail guide is not smooth or too tight	Malfunction of guide-way jib	Adjust the regulating screws on both ends of jib
16	Feedrate doesn't reach the looted feedrate	The safety clutch of the apron is loosed	Regulate the clutch
17	No feed motion when the feed operating lever is lapped	<ol style="list-style-type: none"> <li>1. Spindle not started</li> <li>2. Screw curling change lever is not placed in right-hand position</li> <li>3. Other thread pitches change lever is not set to its proper position</li> </ol>	<ol style="list-style-type: none"> <li>1. Start the spindle</li> <li>2. Turn the screw curling change lever to the right-hand position</li> <li>3. Check and ensuring the change lever in correct position</li> </ol>
18	Over-cutting of thread pitches	<ol style="list-style-type: none"> <li>1. Lead-screw slip</li> <li>2. Split-nutgib is loosed</li> <li>3. Two much clearance between the split-nut and lead-screw</li> </ol>	<ol style="list-style-type: none"> <li>1. Adjust the bearing clearance of the lead-screw</li> <li>2. Adjust the jib screw of split-nut bracket</li> <li>3. Adjust the regulating screw of clearance on splitenut bracket</li> </ol>

• 云南机床厂

No.	Trouble	Probable Cause	Corrections
19	Surface roughness of machined parts	<ol style="list-style-type: none"> <li>1. Dull edge, the edges has been poorly ground and incorrect geometrical angle</li> <li>2. The onset is not clamped and improper tool tip height, too long stretch of the tool tip</li> <li>3. Workpiece not work supporting</li> <li>4. Insufficient work supporting</li> <li>5. Improper cutting amount</li> <li>6. Too much clearance of the spindle bearing</li> <li>7. Uneven foundation or poor-leveling of the machine</li> </ol>	<ol style="list-style-type: none"> <li>1. Analyze the cutting edge regrind the edge</li> <li>2. Fix the insert correctly</li> <li>3. Clean the chuck tail-stock sleeve quill tape bore or replace, chuck center, then reclaim and fix the workpiece</li> <li>4. Use tail-stock center or steady for supporting</li> <li>5. Change feedrates and spindle speed</li> <li>6. Readjust spindle bearing</li> <li>7. Check the foundation and leveling of the machine</li> </ol>
20	Over-dimension of the components in processing	<ol style="list-style-type: none"> <li>1. Breakage of the turning inserts or unclamped</li> <li>2. Unevenness of the clamping surface of chuck or drift of tail-stock quill</li> <li>3. Improper setup level of the machine</li> <li>4. Too much clearance in saddle, upper and below tool-slide and guide-way</li> </ol>	<ol style="list-style-type: none"> <li>1. Regrinding the edge and reclamp the inserts</li> <li>2. Replace the chuck, clamping jowls or adjust tail-stock quill</li> <li>3. Check the setup level of the machine evenly</li> <li>4. Adjust the platen of guide-way and jib</li> </ol>



• 云南机床厂

---

#### **D. Troubleshooting and precautions**

- (1) Eve-belt drive shouldn' t be tensioned too much, to prevent the belt from heat generation.**
- (2) The spindle bearing should be adjusted correctly, the trial running test of 2 hours at maximum speed will be carried out after above adjustment being finished. Final temperature of the spindle doesn't excel 70° centigrade, if not, the bearing must be readjusted.**
- (3) Adjust suspending bearing of the tailstock with the tailstock being clamped, to avoid damage to the bearing as a result of maladjutmit.**
- (4) Reassemble the square toolslide after cleaning according to the corresponding positions specified in maintenance diagram to avoid malfunction of mechanism.**
- (4) Care should be taken not making the safety clutch on the carriage too tight, for ensuring the longitudinal feeding force not exceed 3500N, or otherwise it may lose the effectiveness for safeguard.**

MACHINERYHOUSE

---

## ✦ XI. Digital display unit

The machine is equipped with grating scale and digit display unit of single-coordinate or dual-coordinate according to customers' request.

Digit display unit make it possible to display the displacements of toolslide in both cross travel(x) or transverse, longitudinal travel of X.Y, with resolution 0.005mm in transverse, 0.01mm in longitudinal.

—Operator can read directly the machining dimensions through the panel instead of shutdown the machine for inspection.

—The operator just put his concentrations on the conversion function between absolute mode and incremental mode of digit display unit, to move the toolslide according to the dimensions in absolute or incremental mode without the need for counting.

—By means of presetting functions of digit display unit, any desired entry may be presented in advance into the digit display unit, then move the toolslide to perform parts machining of repeated dimensions, tool offset compensations can also be realized.

—By means of English/metric switching function, any dimensions whether its in English or metric system can be machined by the operator without the need for counting.

### 1. Distribution of digit display unit

The distribution of digit display unit is shown in Fig.11-1.

### 2. Technical parameters of digit display unit

Please read through the operating manual the manufacturer supplied concerning some critical technical parameters of the digit display and grating displacement transducer. This operating manual only supply to those who purchase our machine with digit display unit.

### 3. Operation of digit display unit

Operation of the digit display unit and grating scale please refer to the operating manual the manufacturer supplied us. This instruction is only supply to those who has orders our machine with the digit display unit attached.

### 4. Maintenance service of digital display unit

(1) The digit display unit has been set and tested to certain standard before delivery. Users can't open the enclosure of the grating scale and digit display unit randomly, any alterations and adjustments to the inner equipments and mechanism are forbidden.

• 云南机床厂

---

- (2) The grating head can't be plugged in or pushed out when the unit is in working condition.**
- (3) The transversal plug or longitudinal plug of the grating scale should be plugged in X or Y socket successively without disordering. The power should be switched off when the operation of plugging in or pushing out being actuated.**
- (5) The grating scale must keep clean. Any dirties penetrated should be wiped off gently with absorbent cotton damped in mixture solvents of either. Don't wipe it fiercely or with other solvents, to avoid damage to the surface.**

MACHINERYHOUSE

• 云南机床厂

Fig. 11-1

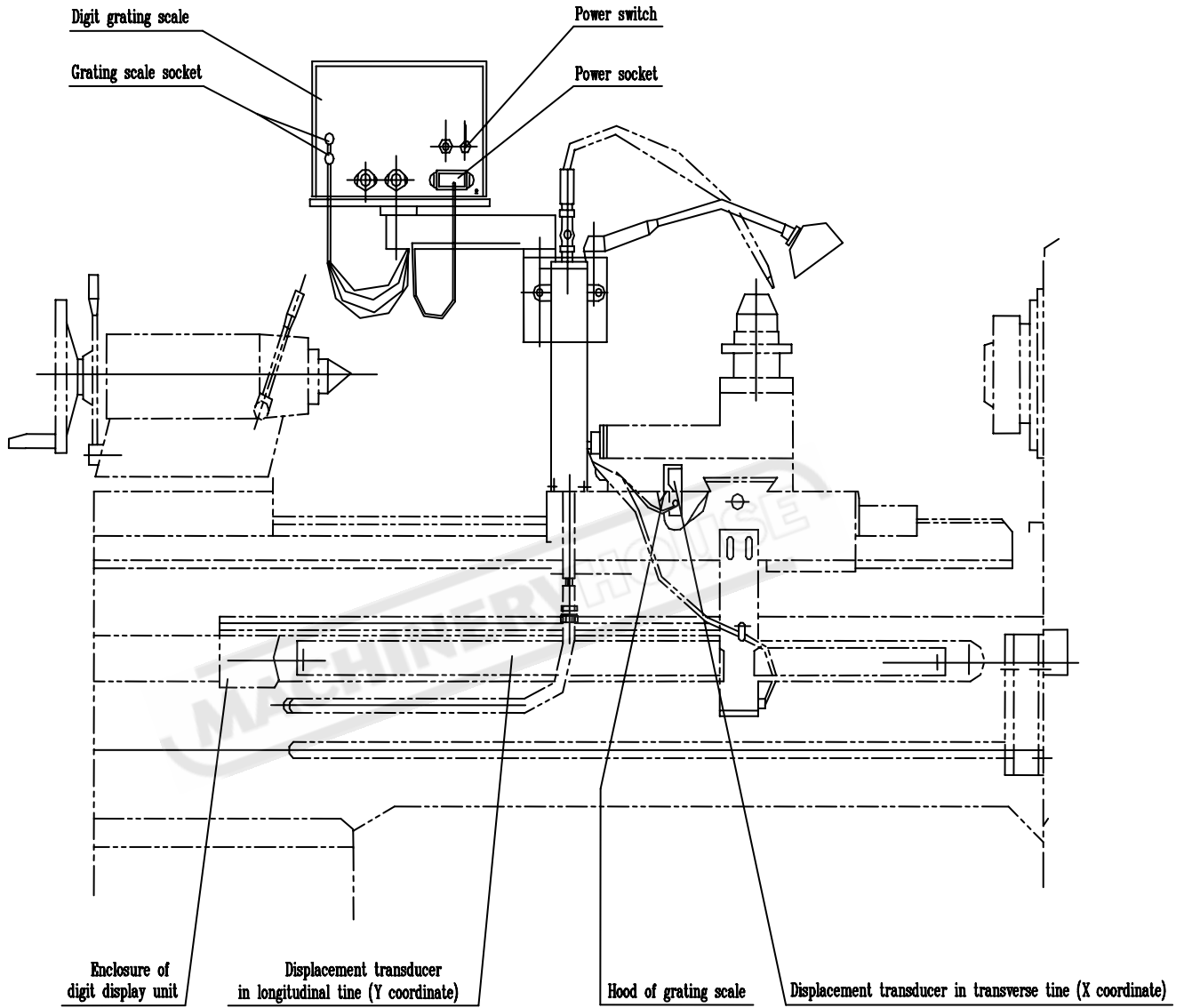

• 云南机床厂

## ❖ XII. Special subordinate equipments

The machine is provided with various special subordinate equipments to expand the machining capability and operation facility. Other special equipments are available at the customer's request.

### PM-04000/B Single Toolslide

Single tool-carrier is used to hold standard single toolslide with its diameter of 46mm(1 13/16"), Vertical distance between reference surface of the tool carrier and spindle center line is 56mm(2 13/64").

Dismount the original PM-04 toolslide components, and mount this single toolslide in the same way, then put it into operation.

The operation of toolslide is shown in fig 12-1.

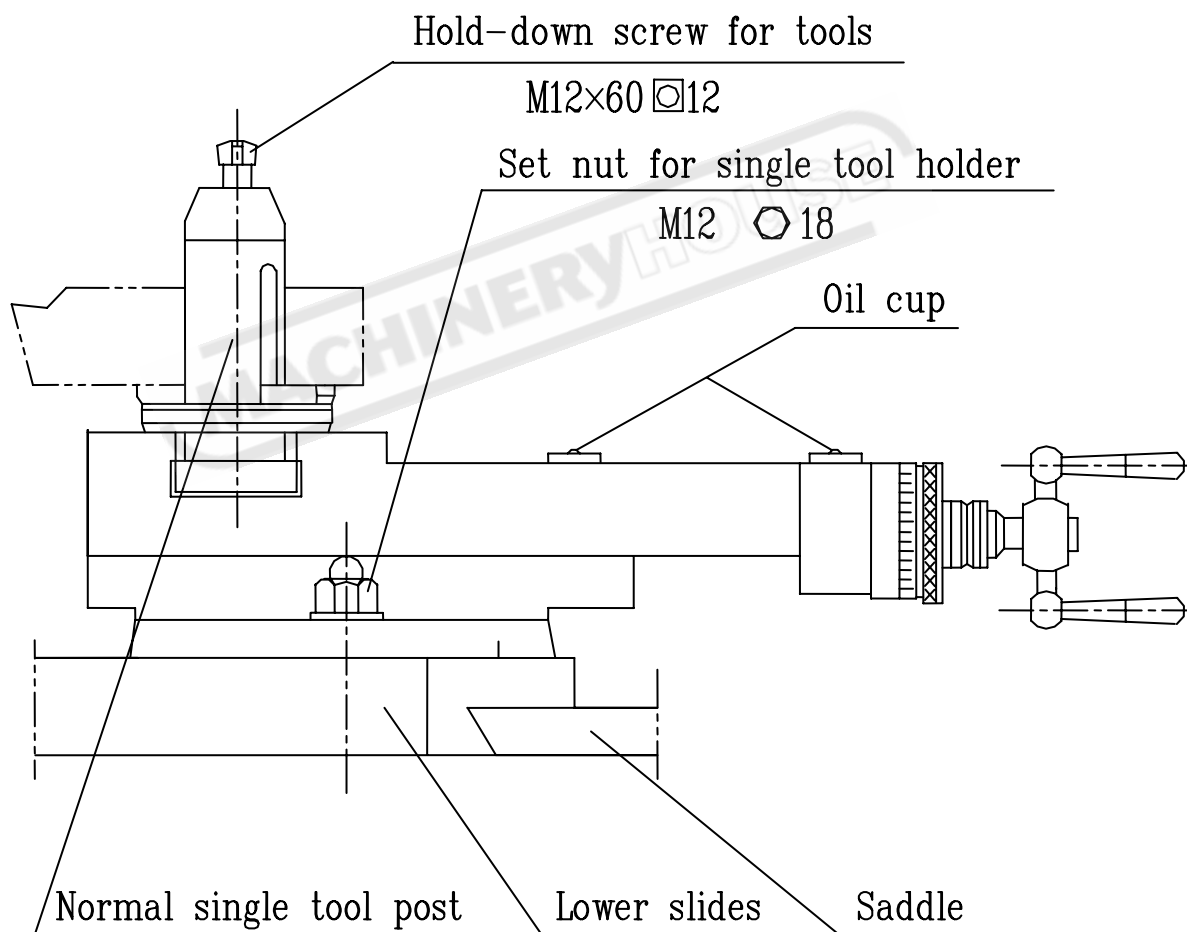

• 云南机床厂

### PM-12000 Taper copyrule

#### PM-12000 Taper copyrule

The taper copyrule available with the machine is mounted and clamped at the rear of the saddle; The fixed trestle of connecting slide table is mounted at the rear guideway of the bed by the use of holddown plate according to machining positions of workpiece.

The slide block linking transverse leadscrew will make a transverse movement along the slanted guideway, and longitudinally move the toolslide to obtain the resultant movement of longitudinal and transverse, thus taper work machining can be realized. The maximum tilting angle is 10°, maximum taper length is 300mm(12").

Release the connecting point between the link rod of the slides table and fixed bracket, remove the bracket, normal turning can be performed.

This taper copyrule is shown in Fig.12-2.

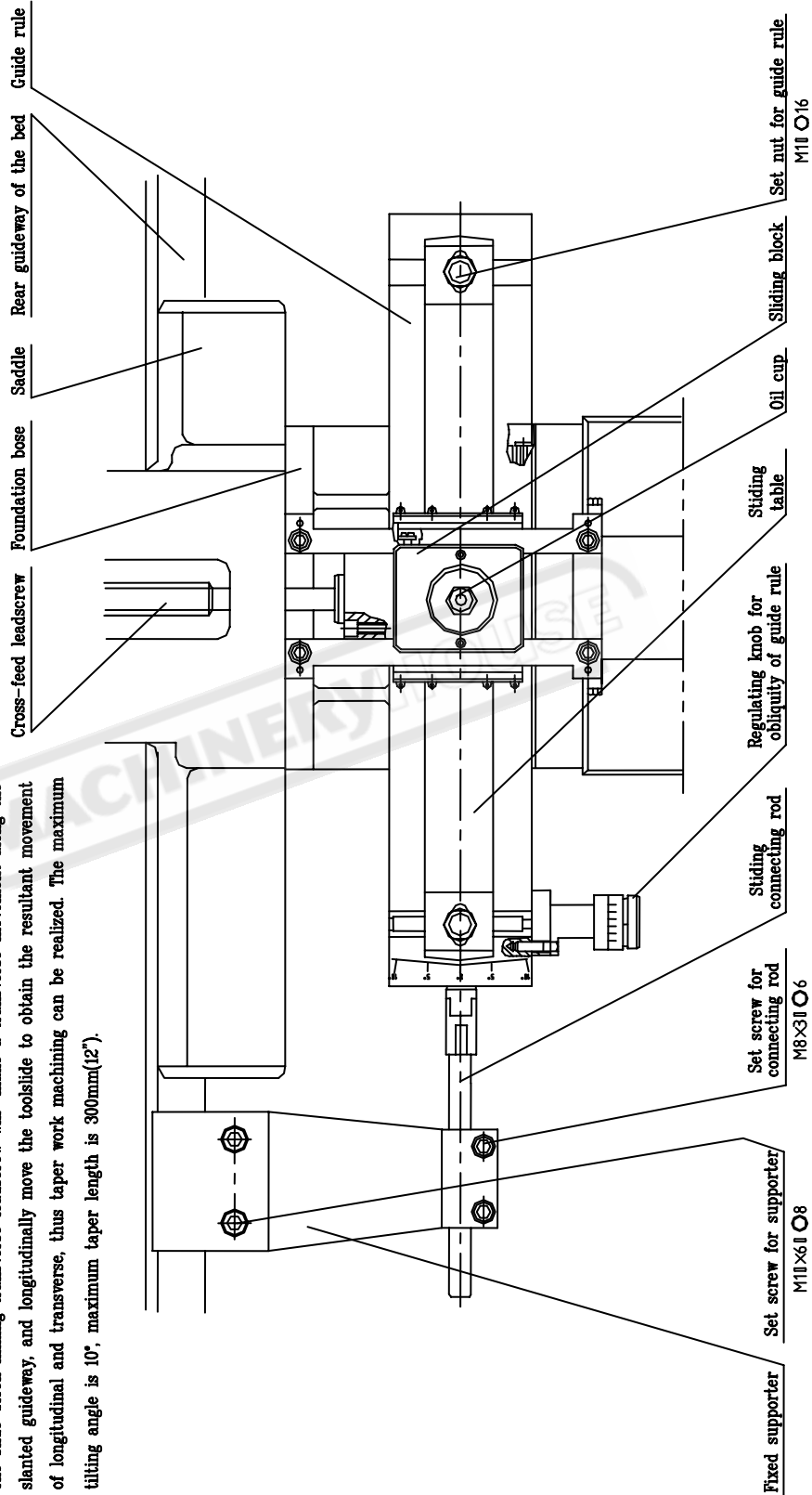

• 云南机床厂

---

### **AB21000 Thread chasing dial**

The thread chasing dial is mounted on the right side of the saddle with its gear engaged with the leadscrew to enable the gear and the axle of gauge pace to rotate simultaneously.

The drive leadscrew is longitudinally moved by the apron to the corresponding thread in inch system or metric system to directly actuate the chasing dial, and the relative inch or metric threadpitch is provided separately to prevent the chasing error of the split nut from occurring.

The thread chasing dial for metric leadscrew is isometrically graduated in 15 short and long lines to mark certain metric threadpitches and closing graduations positions of one, three, and five graduations; The thread chasing dial for inch leadscrew is isometrically graduated in 16 short and long lines to mark certain inch threadpitches and closing graduation positions of one, four, eight and sixteen graduations.

**Note:** This thread chasing dial can be effectively used to prevent chasing error arising from inch threadcutting by metric leadscrew or metric threadcutting by inch leadscrew.

The depth for threadcutting is controlled and restricted by the transverse limited dogs on the right side of lower turret.

When threadcutting is no longer performed, release the setscrew, make the tread chasing dial disengaged from leadscrew, then this device is out of function.

• 云南机床厂

Fig 12-3

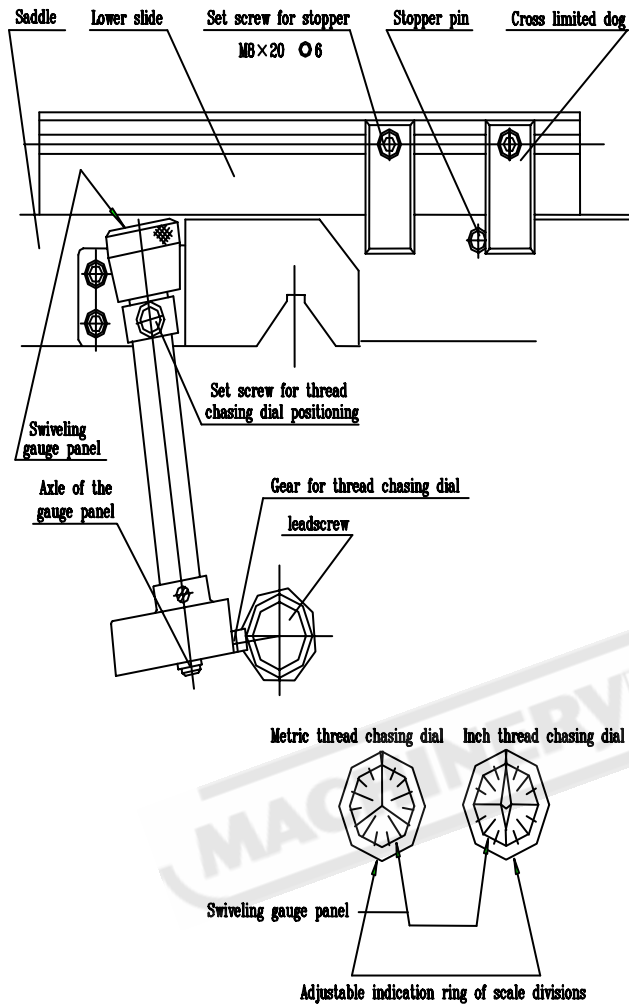

$t$ mm	t	X	t	X	t	X	t	X
0.5	1	2	1	4.5	3	12	1	
0.75	1	2.25	3	5	5	18	3	
1	1	2.5	5	6	1	20	5	
1.25	5	3	1	9	3	36	3	
1.5	1	4	1	10	5			

$n/1''$	n	X	n	X	n	X	n	X
28	1	12	1	4 1/2	4	1 1/4	8	
27	2	11 1/2	4	4	1	1 1/8	16	
24	1	11	2	3 1/2	4	1	2	
22	1	10	1	3	2	7/8	16	
20	1	9	2	2 3/4	8	3/4	8	
19	2	8	1	2 1/2	4	5/8	16	
18	1	7	2	2 1/4	8	1/2	4	
16	1	6	1	2	1	3/8	16	
14	1	5 1/2	4	1 3/4	8	1/4	8	
13	2	5	2	1 1/2	4	1/8	16	



• 云南机床厂

**AB23100 Four-way longitudinal limited dogs(Fig 12-4)**

AB23100 Four-way longitudinal limited dogs

The four-way longitudinal limited dog is mounted on the left side of the front guideway by the serrated holddowns which is built into the rack according to the desired position of workpiece processing.

By rotating the drum of limited dogs and by the use of top portions of four pull-rods, four movable positions of the saddle will be controlled and restricted.

Maximum telescoping amount of pull-rod: 125mm(5?) construction of this four-way longitudinal limit dog is shown in Fig.12-4.

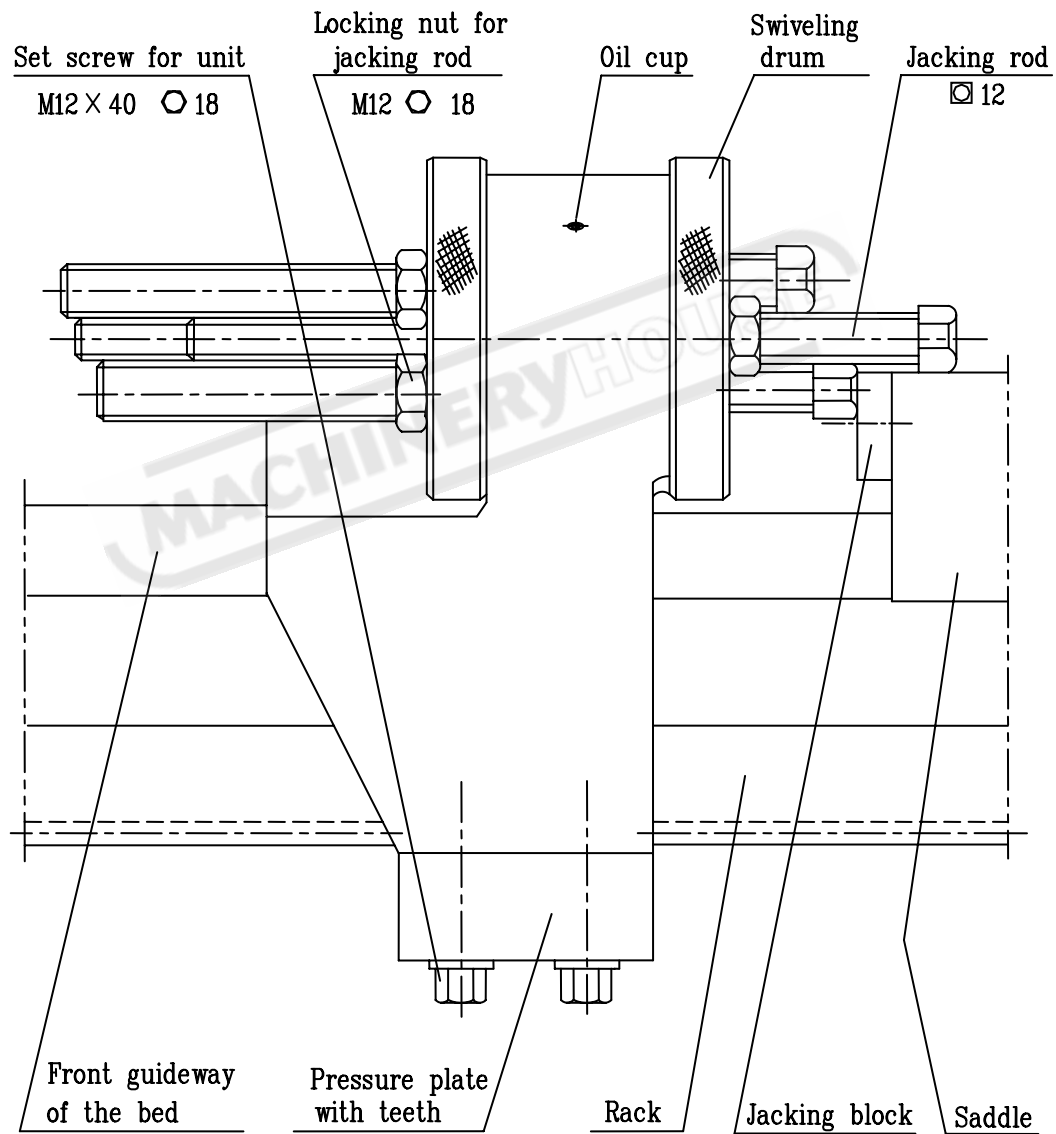

Fig. 12-4

• 云南机床厂

### AB22200 Four-way transversal limited dogs(Fig 12-5)

The four-way transversal limited dog is fixed and mounted on the right side of the guideway, by routing the drum of limited dog and by the use of top portions of the four pull-rods, this limited dog is mounted on the right side of lower slide, to keep contact with the stop pins in the T-type groove, thus the four movements of lower slide are controlled and restricted.

Maximum telescoping amount of pull-rod: 125mm(5").

Construction of this four-way longitudinal limit dogs is shown in Fig.12-5.

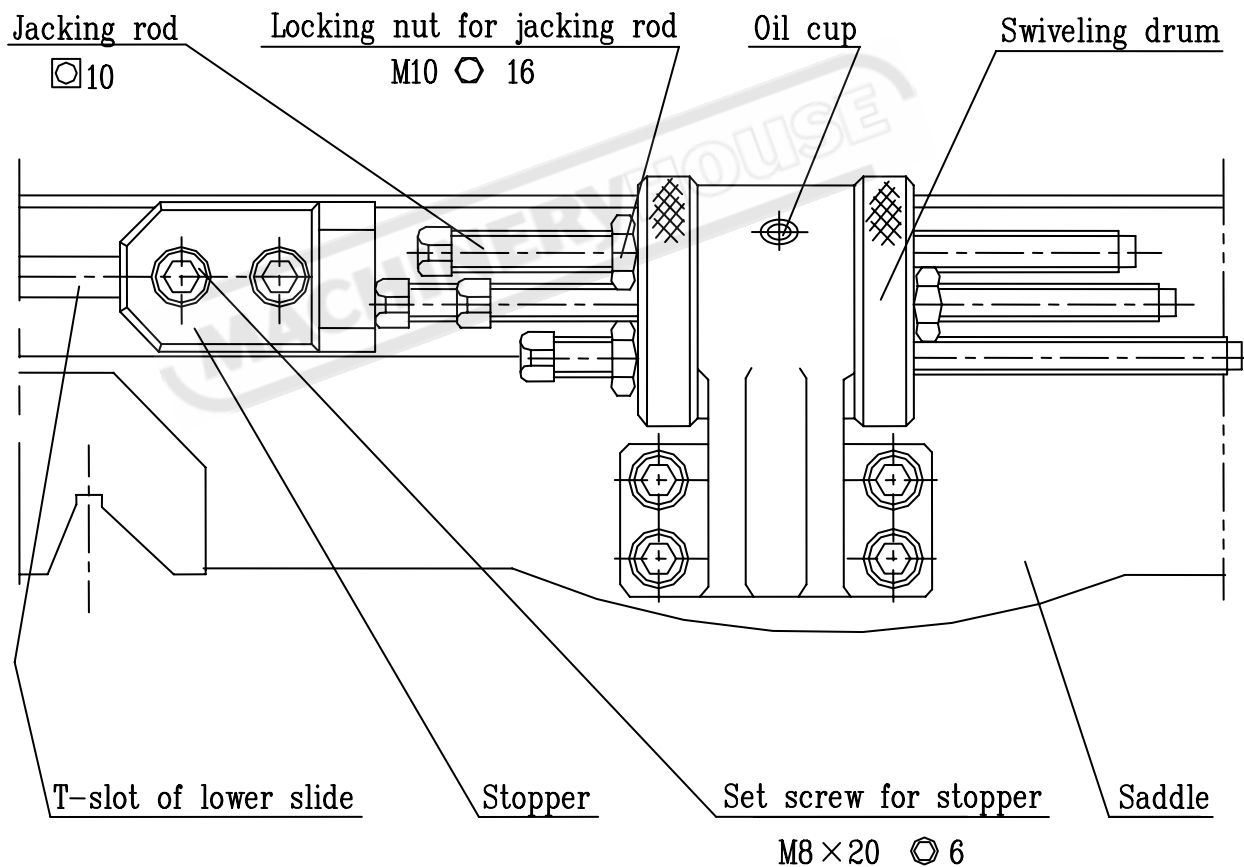

Fig 12-5

• 云南机床厂

### AB22500 Longitudinal limited dog with microadjustment(Fig 12-6)

The longitudinal limited dog with microadjustment is mounted on the left side of rack according to the desired position of workpiece being machined. The movement of the saddle is controlled and restricted by the top portions of pull-rods with microadjustment.

Maximum telescoping amount of pull-rod: 125mm(5").

The pull-rod will move 1mm(0.05") in a complete revolution of the pull-rod ring, there are 0.02mm(0.001") per division.

Outline construction of this device is shown in Fig.12-6.

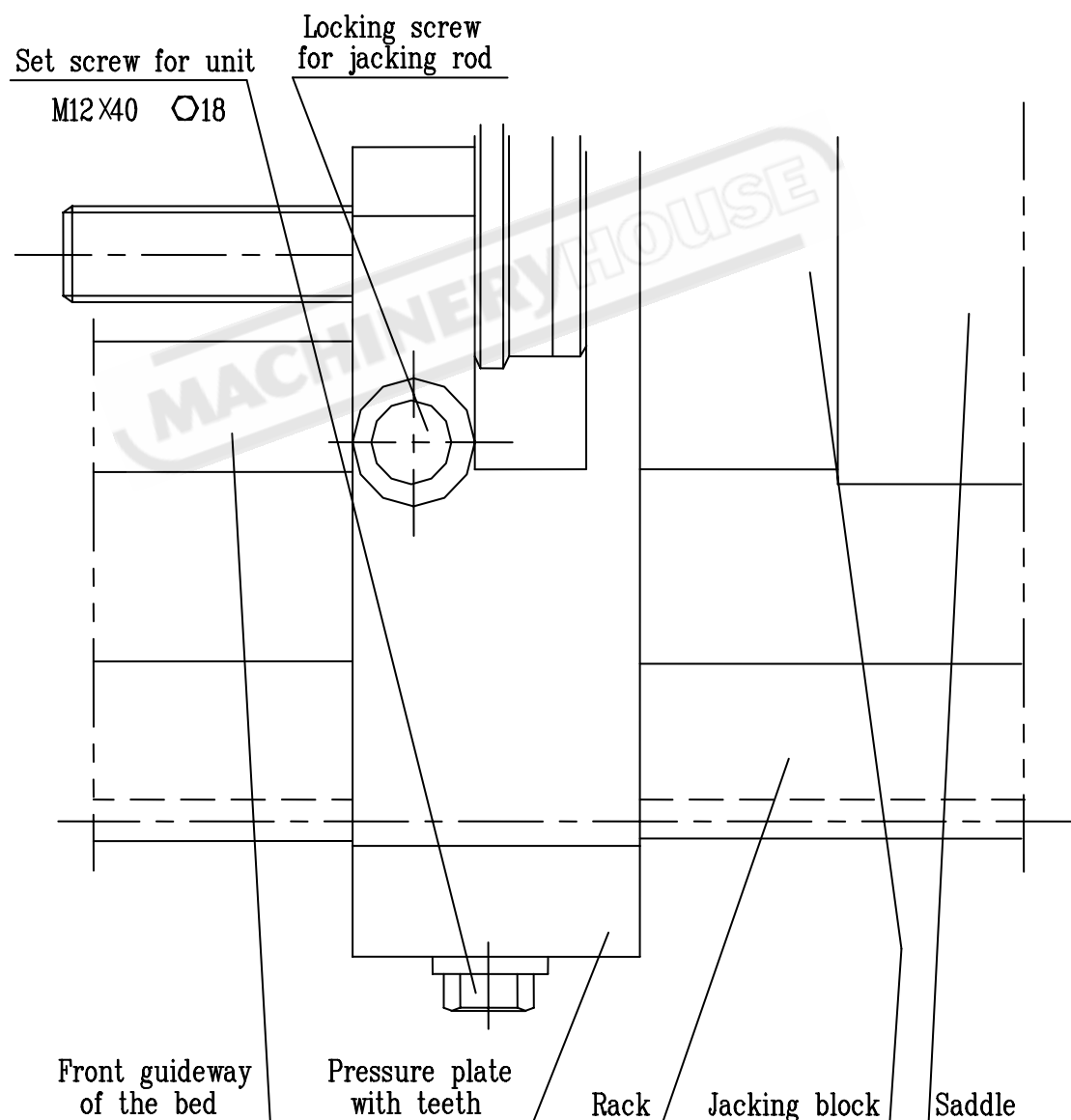

### ✦ XIII. Attachments

Other necessary attachments can be attached according to customer' s requirements.

#### 1. Chuck

Both three-jaw scroll chuck and four jaw independent chuck are available; When the spindle nose of A-type is employed, two kinds of chuck can be installed via direct connecting with spindle nose; When the spindle nose of D-type is employed, two kinds of chuck can be alternatively installed via linear connecting with spindle nose or transition plate connecting with spindle nose.

Diameter specification of the chuck is supplied according to the spindle nose.

Normal distribution for A8: three-jaw chuck 315mm(12").

four-jaw chuck 400mm(16").

other choice with 320mm(12") of four-jaw chuck is also available with the A8.

Normal distribution for A11: three-jaw chuck 400mm(16")

Normal distribution for D8: three-jaw chuck 315mm (12")

four-jaw chuck 400m(16")

other choice with 250mm(10") of three-jaw chuck and 320mm(12") of four-jaw chuck is also available with this D8.

Normal distribution for D11: three-jaw chuck 315mm(12")

four-jaw chuck 400mm(16")

other choice with 315mm(12") of three-jaw chuck and 400mm(16") of four-jaw chuck is also available with this D11.

#### 2. Faceplate

Faceplate is only supplied for lathes with saddle and the diameter specifications DP are equipped according to maximum swing over bed(Db)

Db=500mm(20"), Dp=630mm(25")

Db $\geq$ 630mm(25"), Dp=800mm(32")

Various installations for faceplate are available to enable faceplate being connected

• 云南机床厂

with the spindle nose of A8, A11, D8 or D11.

### 3. Steady rest

The steady rest is divided into two kinds according to supporting point contact, one is sliding contractor, the other is rolling contractor which is suitable for various specifications of this series lathes.

Each kind is distinguished by the diameters of workpieces being supported, three kind specifications are available as follows:

sliding style:  $Ds1=20\text{mm}(3/4")\sim 140\text{mm}(5\ 1/2")$

$Ds2=130\text{mm}(3\ 1/8")\sim 260\text{mm}(10\ 1/4")$

$Ds3=250\text{mm}(9\ 7/8")\sim 380\text{mm}(15")$

rolling type:  $DR1=30\text{mm}(1\ 3/16")\sim 160\text{mm}(6\ 5/16")$

$DR2=150\text{mm}(5\ 7/8")\sim 280\text{mm}(11")$

$DR3=270\text{mm}(10\ 5/8")\sim 400\text{mm}(15\ 3/4")$

Steady rest with sliding contractor is provided as a standard equipment or as a optional equipment when maximum length of workpiece is  $\leq 1000\text{mm}(40")$ , with supporting capacity depending upon the maximum swing over bed D6.

lathe with  $D6\leq 500\text{mm}(20")$ :

Normal distribution  $Ds1=20\text{mm}(3/4")\sim 140\text{mm}(5\ 1/2")$

Optional distribution  $Ds2=130\text{mm}(5\ 1/8")\sim 260\text{mm}(10\ 1/4")$

lathe with  $D6\geq 630\text{mm}(25")$ :

Normal distribution  $Ds2=130\text{mm}(5\ 1/8")\sim 260\text{mm}(10\ 1/4")$

Optional distribution  $Ds3=250\text{mm}(9\ 7/8")\sim 380\text{mm}(15")$

Steady rest with rolling contractor is provided as an optional equipment, but lathe with  $D6\leq 500\text{mm}(20")$  is not available with DR3.

### 4. Follow rest

Follow rest is supported by sliding contractor with supporting capacity of DF  $20\text{mm}(3/4")\sim 80\text{mm}(3\ 1/8")$ . Normal distributions are provided with this series lathes of maximum workpiece length exceeds or equal to  $1500\text{mm}(60")$ , if the maximum workpiece length is blow or equal  $1000\text{mm}(40")$ , this follow rest is provided on the user' s request.

• 云南机床厂

#### ✦ XIV. Operating tools

The commonly used operating tools and their applications are given below:

Symbol	Specification	Name of tools	Applications
S77-1	M5	Center	Built into the tailstock quill to hold workpiece
S91-1A	10×12	Double head wrench	Adjust telescoping of both longitudinal and transversal limited blocks, fix the saddle's movement, clamp tools of single toolslide
	16×17	Double head wrench	Fixed tapered tracing device, guide rule rotating device, fix the locking nut of transversal limited dogs
	18×19	Double head wrench	Fix the rotating position of medium toolslide, adjust the transposing gear, fix longitudinal limited block and the locking nut of holding-out rod
S91-2A	30	Single head wrench	Fix the transposing gears holder, fix the steady rest
S91-7	5	Inner-hexagon spanner	Fix the movement of the top slide
	6	Inner-hexagon spanner	Clamp and fix the tapered device the connecting rod of slide plate, fix the position of transversal limited block
	8	Inner-hexagon spanner	Tighten the fixed taper tracing device, fix the bracket position
	10	Inner-hexagon spanner	Adjust the transversal displacement of tailstock
	14	Inner-hexagon spanner	Install the follow rest, install the chuck attached on spindle nose of A8
	16	Inner-hexagon spanner	Install the chuck attached on spindle nose A11

• 云南机床厂

Symbol	Specification	Name of tools	Applications
S92-3	17	Square socket wrench	Clamp the tools on the square toolslide
PM-13002/D8	14	Square head wrench	Install the chuck attached on spindle nose D8
PM-13002/D11	17	Square head wrench	Install the chuck attached on spindle nose D11
	150mm	Screw driver	Screw the idler shift of transposing holder, lubricating grease squeezed by oilplug, open or tighten the cover plate of lubrication acting point
	100cm	Oil gun	Fill oil in the lubricating acted points specified by the machine

## ✦ X V. Optional equipments and function assemblies

Various optional equipments and function assemblies are available to fulfill the increasing needs from different customers, to expand the adaptation of the machine in addition to those function assemblies which have been confirmed without change. Because all these functional equipments and assemblies don't claim to be applied to certain lathe being selected, or they may repel one another, the descriptions hereabout will be helpful for your selection.

### 1. Functions which need to be confirmed in advance

When you place an order for this series lathes, you need to make a choice on the following items concerning these functions available with the machine.

—Make a choice on the specifications of the machine with regards to the maximum swing over bed.

—Make a choice on the specification of Max. Workpiece length.

—Make a choice on the lathes with or without saddle.

—Choices on the spindle nose rang from A8, A11, D8 or D11.

—Choices on the spindle brake, brake band or magnetic brake?

—Choices on the feeding motion, metric or inch or the inch transmission chain No.2.

—Longitudinal operating handwheel of the toolslide, on the right side operation or on the left side operation.

—Choices on the main motor power supply, 7.5KW(10H.P.), 11KW (15H.P.) or 15KW(20H.P.)

—Choices on the three-phase A. C. frequency, 50Hz or 60Hz.

—Choices on the power voltage, 220V, 380V, 420V, or 440V.

### 2. Functional assemblies being confirmed and selected in advance.

Following items concerning functional assemblies of machine's constructor will be confirmed and selected when placing an order for this series lathes.

—Digital display unit for toolslide movements control (once this unit is selected in toolslide transversal movement, other transversal limited devices are not allowed to be selected).

—Taper copy turningdevice.

—Shifting device of tailstock quillmotion.



• 云南机床厂

- 
- Pedal brake for emergency device of toolslide motion.
  - Single-station longitudinal limited device of toolslide motion with microadjustment.
  - Four-station transversal limited device of toolslide motion (once this device is selected, the transversal limited unit for slide transversal motion are not allowed to be used).
  - Thread chasing dial for preventing out of chasing during threadcutting and its transversal limited device.

(For machines which fitted with digit display unit for control toolslide cross motion fitted with digit display unit for control toolslide cross motion or with four-way transversal limited device of toolslide motion are not allowed to use cross limited block.)

- Rear chip guard ( Only available for lathe with Max. workpiece length below or equal to 200mm).
- Rear chip guard for saddle. (Only available for lathes with Max. workpiece length exceeds 300mm)

- Front chip guard of toolslide.
- Chuck cover with power breakdown protection.

### 3. Other optional functions

- Substitute of original single tool carrier of mounting standard single tool rest.
- Substitute of four-square tool rest with two-stations fixed block.
- Three-jaw chuck with D-type transition plate less than one specification in normal distributions. ( refer to attachments of the machine)
- Four-jaw chuck with D-type transition plate less than one specification in normal distributions. ( refer to machine' s attachments.)
- Steady rest with sliding supportier exceeds one specification in normal distributions. ( refer to machine' s attachments.)
- Steady rest with rolling supporter.
- Follow rest with Max. workpiece length  $\leq 1000\text{mm}(40\text{'})$ .

• 云南机床厂



Addenda:

Emergency brake

To prevent the situation from getting worse and wore at the time of emergency circumstance occurrence, step down the pedal which was build between the legs. The main power was cut off once the pedals begin step-downed and the brake torque was imposed by the brake hand to the V-belt thus the brake of the main motor and spindle was quickly realized. After completion of above-mentioned operation. If the forward-backward-stop lever of the spindle is in the original position (upward for spindle forward rotation, downward for reversed rotation), then the limited switch mounted on the vertical spindle with stop the machine's restart, to prevent the accident from happening. When restart is needed, set the above-mentioned lever to the spindle-stop position and operate the start pushbutton of the main motor.

MACHINERYHOUSE

• 云南机床厂

Operation element and their locations (Fig 2)

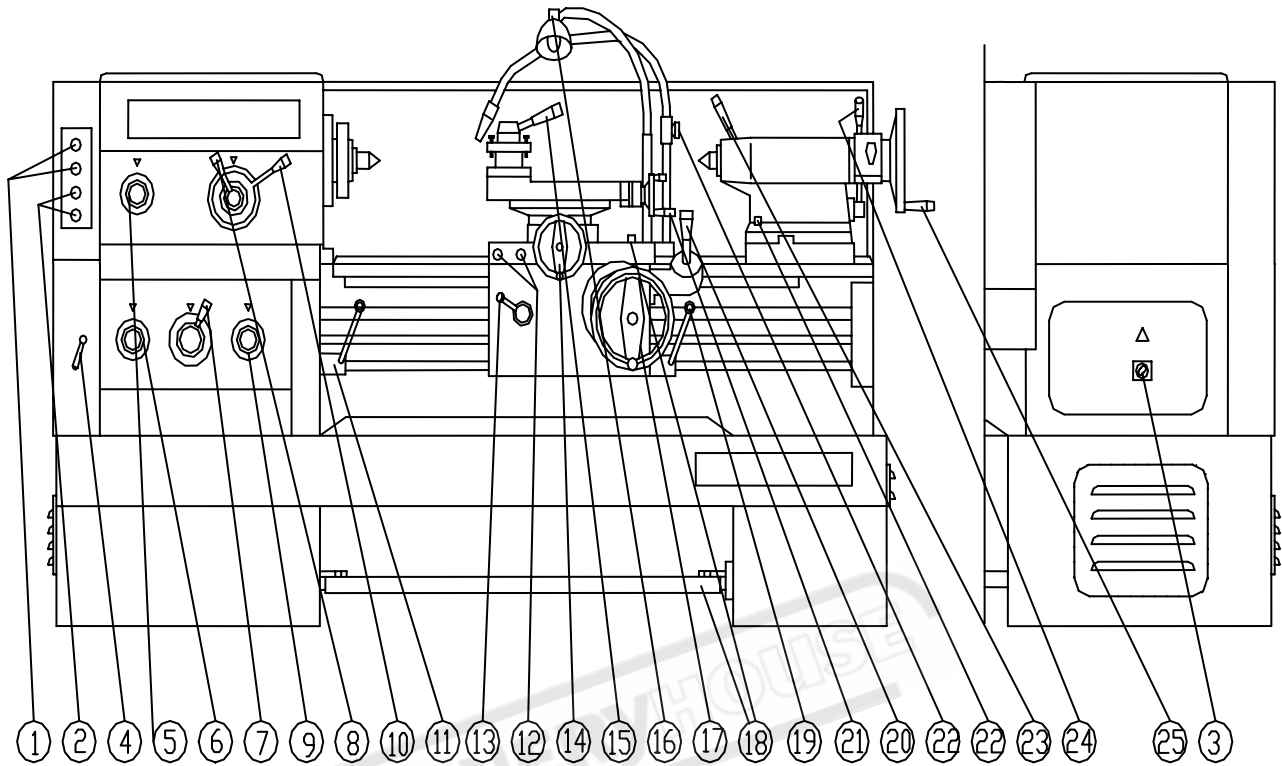

- |   |  |   |                                  |
|---|--|---|----------------------------------|
| 1. Publish-button control of coolant pump                       | 8. Main spindle speed change lever           | 15. Square turret turning clamping handle             | 21. Top slide trave lever        |
| 2. Publish-button control of main drive motor                   | 9. Feedbox multiplying gear change lever     | 16. Lamp switch                                       | 22. Coolant flow regulating lock |
| 3. Cover switch   | 10. Main spindle speed change lever          | 17. Saddle longitudinal travel hand wheel             | 23. Quill clamping handle        |
| 4. Pulley-guard clamping lever                                  | 11. Main spindle forward-brake-reverse lever | 18. Lock screw of saddle                              | 24. Tail stock clamping handle   |
| 5. Normal and amplified pitches, forward and reverse feed lever | 12. Push-button control of main motor        | 18. Spindle brake pedal                               | 25. Quill travel hand wheel      |
| 6. Feed and thread variety dial knob                            | 13. Split-nut closing and releasing lever    | 19. Main spindle forward-brake-revers lever           |                                  |
| 7. feedbox basic gear ratio change lever                        | 14. Cross slide traverse ball crank handle   | 20. Four-way power-feed lever with rapid-travel lever |                                  |

# **HORIZONTAL LATHE**

## **CERTIFICATE OF QUALIFICATION**

**Model:**

**Swing over bed:**

**Max. work piece length:**

**Produce serial No.:**





**This machine has been tested according to GB4020 and is found qualified for delivery.**

**MACHINERYHOUSE**

**Director**

**Chief of Inspection Department**

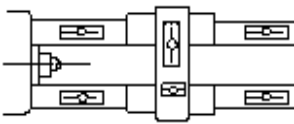
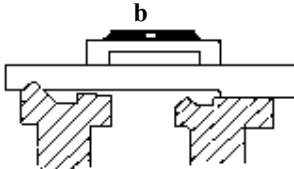
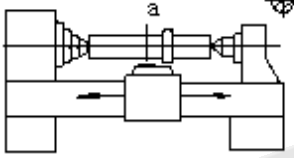
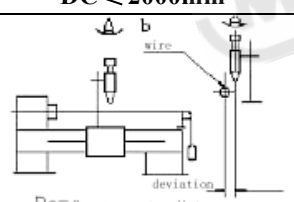
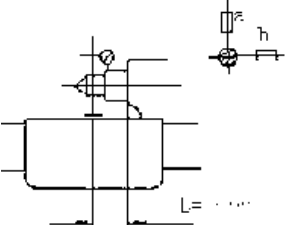
**Date:**

No.	Diagram	Object	Variations		mm
			Permissible		Measured
			$D_c$	$D_a$	$D_a \leq 800$
G1	 <p>a</p>	<p>Verification of leveling of slide-ways</p> <p>a) Longitudinal verification: Straightness of slide-ways in the vertical plane. (convex)</p>	$\leq 500$	0.01	
			750	0.02	
			1000	0.02	
			For any		
			250	0.0075	
			1500	0.025	
			2000	0.03	
			3000	0.04	
			4000	0.05	
			5000	0.06	
For any					
500	0.015				
G2	 <p>b</p>	<p>b) Transverse verification: Slide-ways should be in the same plane.</p>	0.04/1000		
G3	 <p>a</p> <p>DC <math>\leq 2000</math>mm</p>  <p>b</p> <p>wire</p> <p>deviation</p> <p>DC = For any centre distance</p>	<p>Checking of straightness of carriage movement in a horizontal plane or, possibly in a plane defined by the axis of the centres and the tool point.</p>	$\leq 500$	0.015	
			750	0.02	
			1000	0.02	
			1500	0.023	
			2000	0.025	
			3000	0.03	
			4000	0.03	
			5000	0.03	
			For any		
			500	0.015	
G3	 <p>a</p> <p>L = ...</p>  <p>b</p>	<p>Checking of parallelism of tail-stock to carriage movements:</p> <p>a) in the horizontal plane;</p> <p>b) in the vertical plane.</p>	$\leq 500$	a&b 0.03	a)
			750	0.03	
			1000	0.03	
			1500	0.03	
			For any		
			500	0.02	
			> 1500	0.04	
			For any		
			500	0.03	
			<p>Before being checked on all the tests the machine in free state on ground has been leveled to accuracies of 0.04mm per. meter longitudinally and 0.03/1000mm transversely.</p> <p>• <math>D_a</math> = maximum remissible diameter above the bed. <math>D_c</math> = distance between centre.</p>		

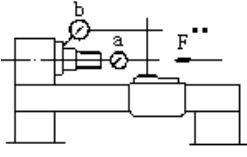
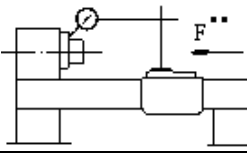
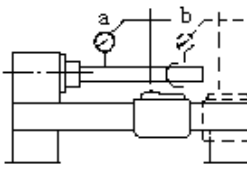
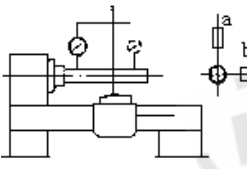
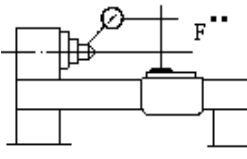
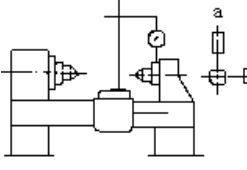
No.	Diagram	Object	Variations	
			mm	
			Permissible	Measured
			• $Da \leq 800$	• $Da \leq 800$
G4		<p>a) Measurement of periodic axial slip.</p> <p>b) Measurement of camming of the face plate resting surface.</p>	<p>a) 0.01</p> <p>b) 0.02</p>	<p>a)</p> <p>b)</p>
G5		Measurement of run-out of spindle nose centring sleeve	0.01	
G6		<p>Measurement of run-out of axis of centre:</p> <p>a) at the spindle nose of the housing;</p> <p>b) at a distance from the spindle nose 300mm.</p>	<p>a) 0.01</p> <p>b) 0.02</p> <p>for a measuring length of 300</p>	<p>a)</p> <p>b)</p>
G7		<p>Checking of parallelism of spindle axis to carriage longitudinal movement</p> <p>a) in the vertical plane;</p> <p>b) in the horizontal plane.</p> <p>Test condition, Run hot the machine at a medium speed up to stable temperature.</p>	<p>a) 0.02/300 upwards</p> <p>b) 0.015/300 frontwards</p>	<p>a)</p> <p>b)</p>
G8		Measurement of run-out of centre.	0.015	
G9		<p>Checking of parallelism of the axis of the outside of tail-stock sleeve to carriage movement:</p> <p>a) in the vertical plane;</p> <p>b) in the horizontal plane.</p>	<p>a) 0.015/100 upwards</p> <p>b) 0.01/100 frontwards</p>	<p>a)</p> <p>b)</p>
<p>• • F = constant pressure on spindle to eliminate axial bearing end play</p>			<p>• Da = maximum permissible diameter above the bed.</p>	

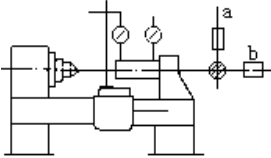
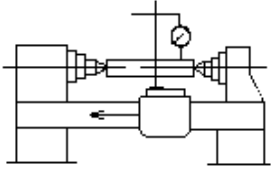
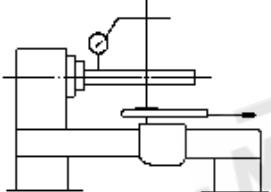
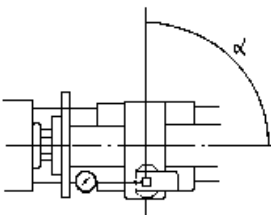
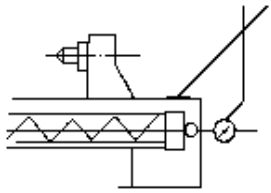
No.	Diagram	Object	Variations mm	
			Permissible	Measured
			• $Da \leq 800$	• $Da \leq 800$
G10		<p>Checking of parallelism of taper bore of sleeve to carriage movement</p> <p>a) in the vertical plane;</p> <p>b) in the horizontal plane.</p>	<p>a) 0.03/300 upwards</p> <p>b) 0.03/300 frontwards</p>	<p>a)</p> <p>b)</p>
G11		<p>Checking of difference in height between head-stock and tail-stock centres.</p> <p>Test condition, Run hot the machine at a medium speed up to stable temperature.</p>	<p>0.04</p> <p>Tail-stock centre higher than head-stock centre</p>	
G12		<p>Checking of parallelism of the longitudinal movement of the upper slide to the spindle axis.</p>	<p>0.04/300</p>	
G13		<p>Measurement of squareness of the transverse movement of the cross slide to the spindle axis.</p> <p>Test condition, Run hot the machine at a medium speed up to stable temperature.</p>	<p>0.02/300</p> <p><math>\alpha \geq 90^\circ</math></p>	
G14		<p>Measurement of periodic axial slip due to camming of each thrust bearing.</p>	<p>0.015</p>	

•  $Da$  = maximum permissible diameter above the bed.

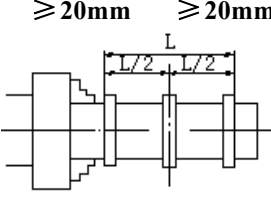
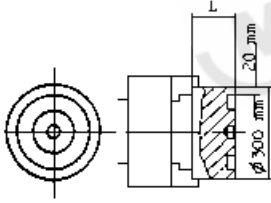
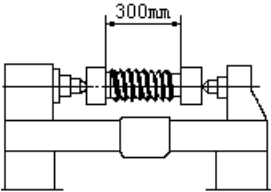

No.	Diagram	Object	Variations	
			mm	
			Permissible	Measured
			• $D_a \leq 800$	
G15		Checking of the cumulative error generated by the lead screw.	For any length of 300	
			$D_c \leq 2000$	0.04
			3000	0.045
			4000	0.05
			5000	0.05
			For any length of	
			60	0.015
P1	 <p> <math>\geq 20\text{mm}</math>    <math>\geq 20\text{mm}</math>  <math>D \geq D_a/8</math>  <math>L = D_a/2</math> </p>	Machining of cylindrical test-pieces held in a chuck (the cylindrical test-piece maybe inserted in the taper bore of the spindle). a) roundness b) cylindricity	a) 0.01	a)
			b) 0.03	
			$L=300$ Any taper shall be such that the major diameter is near head-stock surface finish not less than $\nabla 6$	
P2	 <p> <math>L_{max} = D_a/8</math> </p>	Machining of cylindrical pieces held in a chuck.  Flatness	For a diameter of 300	
			0.02 (concave)	
			surface finish not less than $\nabla 6$	
P3	 <p> <math>L=300\text{mm}</math> </p>	Threading of a cylindrical piece  $L=300\text{mm}$  ISO triangular thread (ISO 68)	For any 300	
			$D_c \leq 2000$	0.04
			3000	0.045
			4000	0.05
			5000	0.05
			For any	
			50	0.015
			The screw thread shall be clean without flats or waviness.	
• $D_a$ = maximum permissible diameter above the bed. $D_c$ = distance between centre.				

## CL SERIES HORIZONTAL LATHE

# PACKING LIST

**Model :**

**Swing over bed :**

**Max. work piece length:**

**Produce serial NO. :**



**I. The main machine****Name: Horizontal Lathe****Quantity: 1 set****Model:**

**Specification: (You are to identify the one which would be the best response to your needs and fill the symbol "√" in the following brackets)**

1. Max. swing over bed—500mm(20" )、 630mm(25" )、 660mm(26" ) ( )
2. Max. workpiece length—750mm(30" )、 1000mm(40" ) ( )、  
1500mm(60" ) ( )、 2000mm(80" ) ( )、 3000mm(120" ) ( )、  
4000mm(160" ) ( )、 5000mm(200" ) ( )
3. Saddle—available( )、 unavailable( )
4. Spindle nose—A8( )、 A11( )、 D8( )、 D11( )
5. Braking mode of the main transmission—brake band ( )、 magnetic brake ( )
6. Type of feed motion—metric ( )、 inch ( )、 the second kind of inch ( )
7. Position of the longitudinal travel operating handwheel of the toolslide on the apron—left side ( )、 right side ( )
8. Three-phase power frequency—50Hz ( )、 60Hz ( )
9. Power voltage—220V( )、 380V( )、 420V( )、 440V( )
10. Main motor—7.5KW(10HP)( )、 11KW(15HP)( )、 15KW(20HP)( )

**II. Operating tools ( in the accessory box )**

- |     |             |       |                                 |         |
|-----|-------------|-------|---------------------------------|---------|
| 1.  | S77-1       | M5    | Center                          | 2 pc( ) |
| 2.  | S91-1A      | 10×12 | Double-ended spanner            | 1 pc( ) |
| 3.  | S91-1A      | 16×17 | Double-ended spanner            | 1 pc( ) |
| 4.  | S91-1A      | 18×19 | Double-ended spanner            | 1 pc( ) |
| 5.  | S91-2A      | 30    | Single head wrench              | 1 pc( ) |
| 6.  | S91-7       | 5     | Socket screw hexagon wrench     | 1 pc( ) |
| 7.  | S91-7       | 6     | Socket screw hexagon wrench     | 1 pc( ) |
| 8.  | S91-7       | 8     | Socket screw hexagon wrench     | 1 pc( ) |
| 9.  | S91-7       | 10    | Socket screw hexagon wrench     | 1 pc( ) |
| 10. | S91-7       | 14    | Socket screw hexagon wrench     | 1 pc( ) |
| 11. | S91-7       | 17    | Socket screw hexagon wrench     | 1 pc( ) |
| 12. | S92-3       | 17    | Square socket wrench            | 1 pc( ) |
| 13. | S99-2       | 12.1  | Iriangulat sleeve wrench        | 1 pc( ) |
| 14. | PM-13002/D8 | 14    | Square socket wrench (available |         |

		<b>only for spindle nose D8 )</b>	<b>1 pc( )</b>
<b>PM-13002/D11</b>	<b>17</b>	<b>Square socket wrench (available</b>	
		<b>only for spindle nose D11 )</b>	<b>1 pc( )</b>
<b>15. PM-13002</b>	<b>150mm</b>	<b>Screw driver</b>	<b>1 pc( )</b>
<b>16.</b>	<b>100mm</b>	<b>oil gun</b>	<b>1 pc( )</b>
<b>17.PML-13011</b>		<b>Center sleeve</b>	<b>1 pc( )</b>

### III. Accessories

#### 1. Three-jaw chuck ( in the accessory box )

**A8 spindle nose: chuck KY315-A8 (315mm(12"), A8)** **1 set( )**

**A11 spindle nose: chuck KY400-A11(400mm(16"), A11)** **1 set( )**

**D8 spindle nose: chuck KZ315 (315mm(12"))** **1 set( )**

**chuck seat PM-091/D8B(315mm(12"), D8)** **1 set( )**

**D11 spindle nose: chuck KZ400 (400mm(16"))** **1 set( )**

**chuck seat PM-091/D11B(400mm(16"), D11)** **1 set( )**

#### 2. Four-jaw independent chuck, available only for lathes with saddle ( in accessory box )

**A8 spindle nose: chuck KH 400-A8 (400mm(16"), A8)** **1 set( )**

**D8 spindle nose: chuck KN 400 (400mm(16"))** **1 set( )**

**chuck seat PM-093/D8B(400mm)(16"), D8)** **1 set( )**

**D11 spindle nose: chuck KN 500 (500mm(20"))** **1 set( )**

**chuck seat PM-093/D11B(500mm(20"), D11)** **1 set( )**

#### 3. Faceplate, only for lathe with saddle ( on the paperboard of packing box)

##### A8 Spindle nose:

**Max. swing over bed Db=500mm(20")**

**Faceplate PM-094/50 A8(630mm(25"), A8)** **1 set( )**

**Max. swing over bed Db ≥ 630mm(25")**

**Faceplate PM-094/63 A8(800mm(32"), A8)** **1 set( )**

##### A11 Spindle nose:

**Max. swing over bed Db=500mm(20")**

**Faceplate PML-094/50 A11(630mm(25"), A11)** **1 set( )**

**Max. swing over bed Db ≥ 630mm(25")**

**Faceplate PML-094/63 A11(800mm(32"), A11)** **1 set( )**

##### D8 Spindle nose:

**Max. swing over bed Db=500mm(20")**

- 
- Faceplate PM-094/50 D8(630mm(25"))、 D8) 1 set( )  
 Max. swing over bed  $Db \geq 630\text{mm}(25")$
- Faceplate PM-094/63 D8(800mm(32"))、 D8) 1 set( )
- D11 Spindle nose:**
- Max. swing over bed  $Db=500\text{mm}(20")$
- Faceplate PML-094/50 D11(630mm(25"))、 D11) 1 set( )  
 Max. swing over bed  $Db \geq 630\text{mm}(25")$
- Faceplate PML-094/63 D11(800mm(32"))、 D11) 1 set( )
4. **Steady rest:** In addition to special orders, this steady rest is only available for lathes with Max. workpiece length  $Lc \geq 1500\text{mm}(60")$  and Max. swing over bed  $Db=500\text{mm}(20")$
- Steady rest PM-105/50A( $\phi 20\text{mm}(3/4") \sim 140\text{mm}(5\ 1/2")$ )、  $h250\text{mm}(10")$ ) 1 set( )  
 Max. swing over bed  $Db=630\text{mm}(25")$
- Steady rest PM-105/63B( $\phi 130\text{mm}(5\ 1/8") \sim 260\text{mm}(10\ 1/4")$ )、  $h315\text{mm}(12")$ ) 1 set( )
- Max. swing over bed  $Db=660\text{mm}(26")$
- Steady rest PM-105/63B( $\phi 130\text{mm}(5\ 1/8") \sim 260\text{mm}(10\ 1/4")$ )、  $h330\text{mm}(13")$ ) 1 set( )
5. **Follow rest ( $\phi 20\text{mm}(3/4") \sim \phi 80\text{mm}(3\ 1/8")$ ):** In addition to special orders, this follow rest is only available for lathes with Max. workpiece length  $Lc \geq 1500\text{mm}(60")$
- Max. swing over bed  $Db=500\text{mm}(20")$
- Follow rest PM-102/50 ( $h198\text{mm}(7\ 3/4")$ ) 1 set( )  
 Max. swing over bed  $Db=630\text{mm}(25")$
- Follow rest PM-102/63 ( $h263\text{mm}(10\ 3/8")$ ) 1 set( )  
 Max. swing over bed  $Db=660\text{mm}(26")$
- Follow rest PM-102/66 ( $h278\text{mm}(10\ 7/8")$ ) 1 set( )
6. **Foundation bolt pack ( in accessory box)**
- Each set is consisted of:
- J23-8, M20 $\times$  400 bolt 1 pc  
 J12-8, M20, nut 1 pc  
 J51-2, M20, washer 1 pc

**Max. workpiece length  $L_c \leq 1500\text{mm}(60'')$ , foundation bolt**

**pack 6 set( )**

**Max. workpiece length  $L_c=2000\text{mm}(80'')$**

**$L_c=3000\text{mm}(120'')$ , foundation bolt**

**pack 8 set( )**

**$L_c=400\text{mm}(160'')$**

**$L_c=500\text{mm}(200'')$ , foundation bolt**

**pack 10 set( )**

**7. V-belt drive (GB1171)(at the bottom of packing box)**

**Main motor power 7.5KW T10 HPJ**

**Max. swing over bed  $Db=500\text{mm}(20'')$**

**V-belt drive B-2235 (2235mm(88'')) 4 pc.( )**

**Max. swing over bed  $Db=630\text{mm}(25'')$**

**V-belt drive B-2362 (2362mm(93'')) 4 pc.( )**

**Max. swing over bed  $Db=660\text{mm}(26'')$**

**V-belt drive B-2388 (2388mm(94'')) 4 pc.( )**

**Main motor power 11KW(15HP)、15KW(20HP)**

**Max. swing over bed  $Db=500\text{mm}(20'')$**

**V-belt drive B-2184 (2184mm(86'')) 4 pc.( )**

**Max. swing over bed  $Db=630\text{mm}(25'')$**

**V-belt drive B-2311 (2311mm(91'')) 4 pc.( )**

**Max. swing over bed  $Db=660\text{mm}(26'')$**

**V-belt drive B-2337 (2337mm(92'')) 4 pc.( )**

**8. Driving plate: D8 spindle nose. AB09200.( $\Phi$  250) 1set ( )**

**IV. Special subordinate equipments are available on request**

**1. Digit display unit for tool movement control**

**Single-coordinate**

**Cross raster scale and hood ( on the saddle) 1 set( )**

**Digit display unit bracket ( on the saddle) 1 set( )**

**Digit display scale ( in accessory box) GSJ15 (Single-coordinate) 1 set( )**

**Double-coordinate**

**Cross raster scale and hood ( on the saddle) 1 set( )**

**Vertical raster scale and hood (on the bed) 1 set( )**

- 
- |            |   |                 |
|------------|---|-----------------|
|            | <b>Digit display bracket ( on the saddle)</b>                             | <b>1 set( )</b> |
|            | <b>Digit display scale ( in accessory box) GSJ25 (Double-coordinates)</b> | <b>1 set( )</b> |
| <b>2.</b>  | <b>Single-toolslide (with the machine or accessory box)</b>               |                 |
|            | <b>Max. swing over bed Db=500mm(20")</b>                                  |                 |
|            | <b>Single-toolslide PM-04/50B(L160mm(6 1/4")、 h104mm(4 3/32")</b>         | <b>1 set( )</b> |
|            | <b>Max. swing over bed Db=630mm(25")、 660mm(26")</b>                      |                 |
|            | <b>Single-toolslide PM-04/63B(L190mm(7 1/4")、 h146mm(5 3/4")</b>          | <b>1 set( )</b> |
| <b>3.</b>  | <b>Thread chasing dial (on the saddle)</b>                                |                 |
|            | <b>Metric lathe with thread chasing dial AB-21/A</b>                      |                 |
|            | <b>(15 isometric graduations)</b>   | <b>1 set( )</b> |
|            | <b>Inch lathe with thread chasing dial AB-21/B</b>                        |                 |
|            | <b>(16 isometric graduations)</b>   | <b>1 set( )</b> |
| <b>4.</b>  | <b>Taper copy ruler (with the machine)</b>                                |                 |
|            | <b>PM-12((300mm)(12")、 ±10°)</b>  | <b>1 set( )</b> |
| <b>5.</b>  | <b>Four-way longitudinal limited dogs</b>                                 |                 |
|            | <b>(on the saddle) AB-221 (125mm(5"))</b>                                 | <b>1 set( )</b> |
| <b>6.</b>  | <b>Four-way transversal limited dogs</b>                                  |                 |
|            | <b>(on the saddle) AB-222 (125mm(5"))</b>                                 | <b>1 set( )</b> |
| <b>7.</b>  | <b>Longitudinal limited dog with microadjustment</b>                      |                 |
|            | <b>(on the bed) AB-225(125mm(5"))</b>                                     | <b>1 set( )</b> |
| <b>8.</b>  | <b>Emergency pedal brake</b>  |                 |
|            | <b>(between legs of machine) PM-017</b>                                   | <b>1 set( )</b> |
| <b>9.</b>  | <b>Shifting device for tailstock sleeve movement</b>                      |                 |
|            | <b>PM-033</b>   | <b>1 set( )</b> |
| <b>10.</b> | <b>Rear chip guard (below the cover of the packing box)</b>               |                 |
|            | <b>PML-811</b>  | <b>1 set( )</b> |
| <b>11.</b> | <b>Front chip hood of toolslide (on the saddle)</b>                       |                 |
|            | <b>PM-814</b>   | <b>1 set( )</b> |
| <b>12.</b> | <b>Rear chip hood of the saddle (on the saddle)</b>                       |                 |
|            | <b>PM-815</b>   | <b>1 set( )</b> |
| <b>V.</b>  | <b>Accessories supplied according to user's requirements</b>              |                 |
| <b>1.</b>  | <b>Three-jaw self-centering chuck with D-type</b>                         |                 |
|            | <b>transition plate (in the accessory box)</b>                            |                 |

<b>D8 Spindle nose: chuck KZ250 (250mm(10"))</b>	<b>1 set( )</b>
<b>Chuck seat: PM-091/D8A (250mm(10"))、 D8)</b>	<b>1 set( )</b>
<b>D11Spindle nose: chuck KZ315 (315mm(12"))</b>	<b>1 set( )</b>
<b>Chuck seat: PML-091/D11A (315mm(12"))、 D11)</b>	<b>1 set( )</b>
<b>2. Four-jaw independent chuck with D-type transition plate (in the accessory box)</b>	
<b>D8 Spindle nose: chuck KN320 (320mm(12"))</b>	<b>1 set( )</b>
<b>Chuck seat: PM-093/D8A (320mm(12"))、 D8)</b>	<b>1 set( )</b>
<b>D11 Spindle nose: chuck KN400 (400mm(16"))</b>	<b>1 set( )</b>
<b>Chuck seat: PML-093/D11A (400mm(16"))、 D11)</b>	<b>1 set( )</b>
<b>3. Steady rest (on the bed)</b>	
<b>Max. swing over bed Db=500mm(20"))</b>	
<b>Steady rest PM-105/50B</b>	
<b>(<math>\phi</math>130mm(5 1/8"))~260mm(10 1/4"))、 h250mm(10"))</b>	<b>1 set( )</b>
<b>Max. swing over bed Db=630mm(25"))</b>	
<b>Steady rest PM-105/63A</b>	
<b>(<math>\phi</math>20mm(3/4"))~140mm(5 1/2"))、 h315mm(12"))</b>	<b>1 set( )</b>
<b>Steady rest PM-105/63C</b>	
<b>(<math>\phi</math>250mm(9 7/8"))~140mm(5 1/2"))、 h315mm(12"))</b>	<b>1 set( )</b>
<b>Max. swing over bed Db=660mm(26"))</b>	
<b>Steady rest PM-105/66A</b>	
<b>(<math>\phi</math>20mm(3/4"))~140mm(5 1/2"))、 h330mm(13"))</b>	<b>1 set( )</b>
<b>Steady rest PM-105/66C</b>	
<b>(<math>\phi</math>250mm(9 7/8"))~380mm(15"))、 h330mm(13"))</b>	<b>1 set( )</b>
<b>4. Rolling steady rest (on the bed)</b>	
<b>Max. swing over bed Db=500mm(20"))</b>	
<b>Steady rest PM-361/50A</b>	
<b>(<math>\phi</math>30mm(1 3/16"))~160mm(6 5/16"))、 h250mm(10"))</b>	<b>1 set( )</b>
<b>Steady rest PM-361/50B</b>	
<b>(<math>\phi</math>150mm(5 7/8"))~280mm(11"))、 h250mm(10"))</b>	<b>1 set( )</b>
<b>Max. swing over bed Db=630mm(25"))</b>	
<b>Steady rest PM-361/63A</b>	
<b>(<math>\phi</math>30mm(1 3/16"))~160mm(6 5/16"))、 h315mm(12"))</b>	<b>1 set( )</b>
<b>Steady rest PM-361/63B</b>	



- 
- |  |                   |
|--|-------------------|
| <b>(<math>\phi</math>150mm(5 7/8")~280mm(11"), h315mm(12"))</b>      | <b>1 set( )</b>   |
| <b>Steady rest PM-361/66C</b>  |                   |
| <b>(<math>\phi</math>270mm(10 5/8")~400mm(15 3/4"), h330mm(13"))</b> | <b>1 set( )</b>   |
| <b>5. Rapid change tool holder P1325C</b>                            |                   |
| <b>(6 sets of tool holder are attached)</b>                          | <b>1 set( )</b>   |
| <b>6. Swiveling center D415(M5)</b>                                  | <b>1 set( )</b>   |
| <b>7. Damping washer JJD-II(<math>\phi</math>120)</b>                | <b>( ) set( )</b> |

## VI. Technical documents (in the accessory box)

### CL Series

- 1. CL SERIES HORIZONTAL LATHE OPERATION MANUAL 1copy( )**
- 2. HORIZONTAL LATHE CERTIFICATE OF QUALIFICATION  
1copy( )**
- 3. CL SERIES HORIZONTAL LATHE PACKING LIST  
1copy( )**

**Delivery date:**

**Packing date:**

**Packing inspector:**

# 床身部件 BED AND BASE

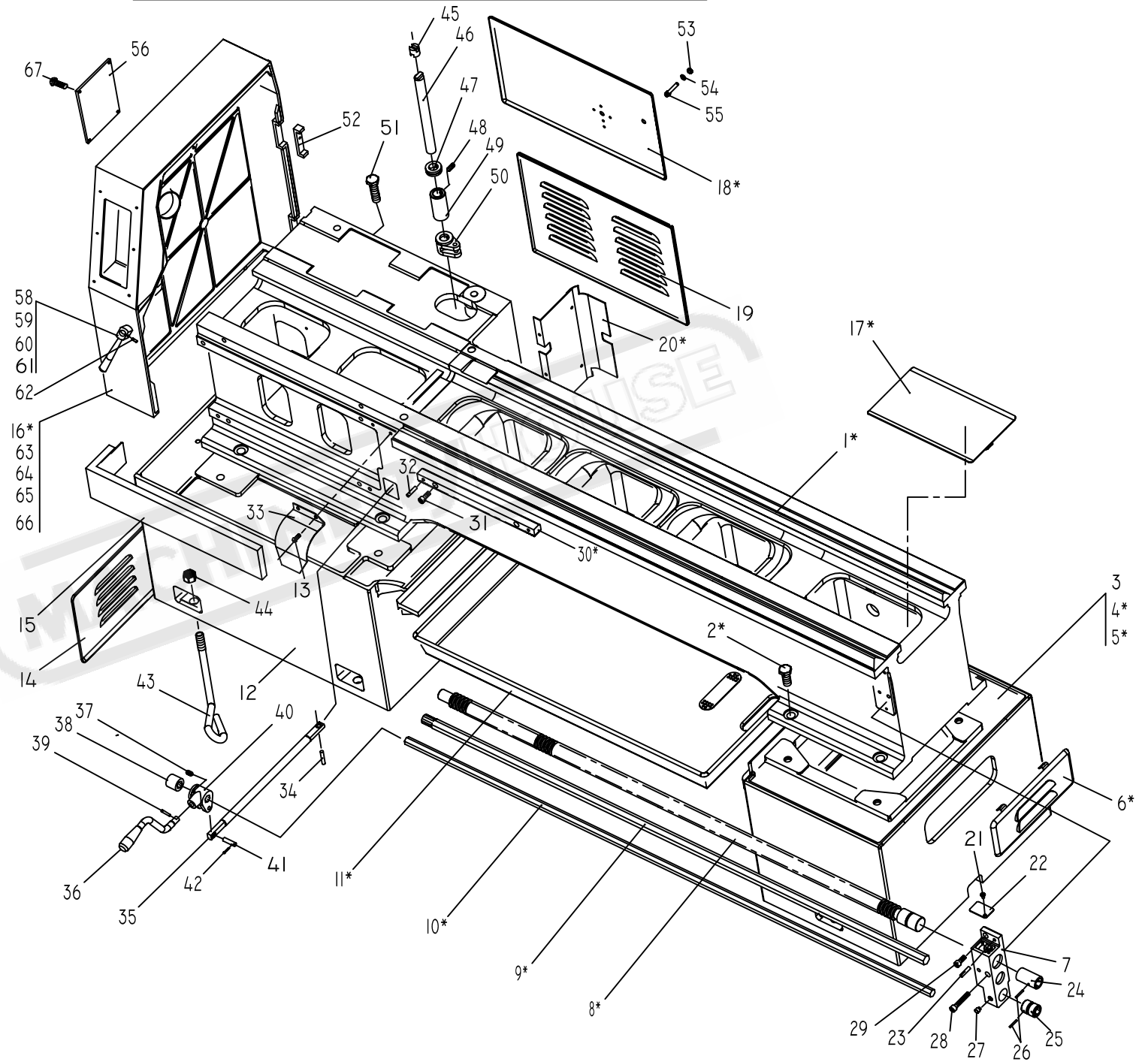

## 主机系统 BRAKE SYSTEM

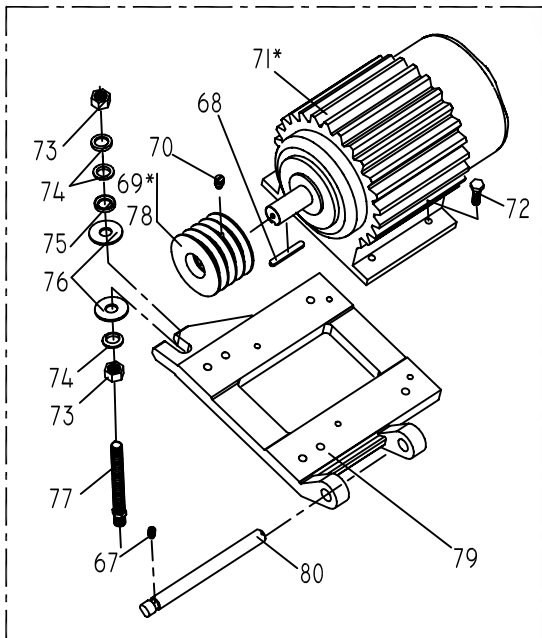

# 床头箱 HEAD STOCK

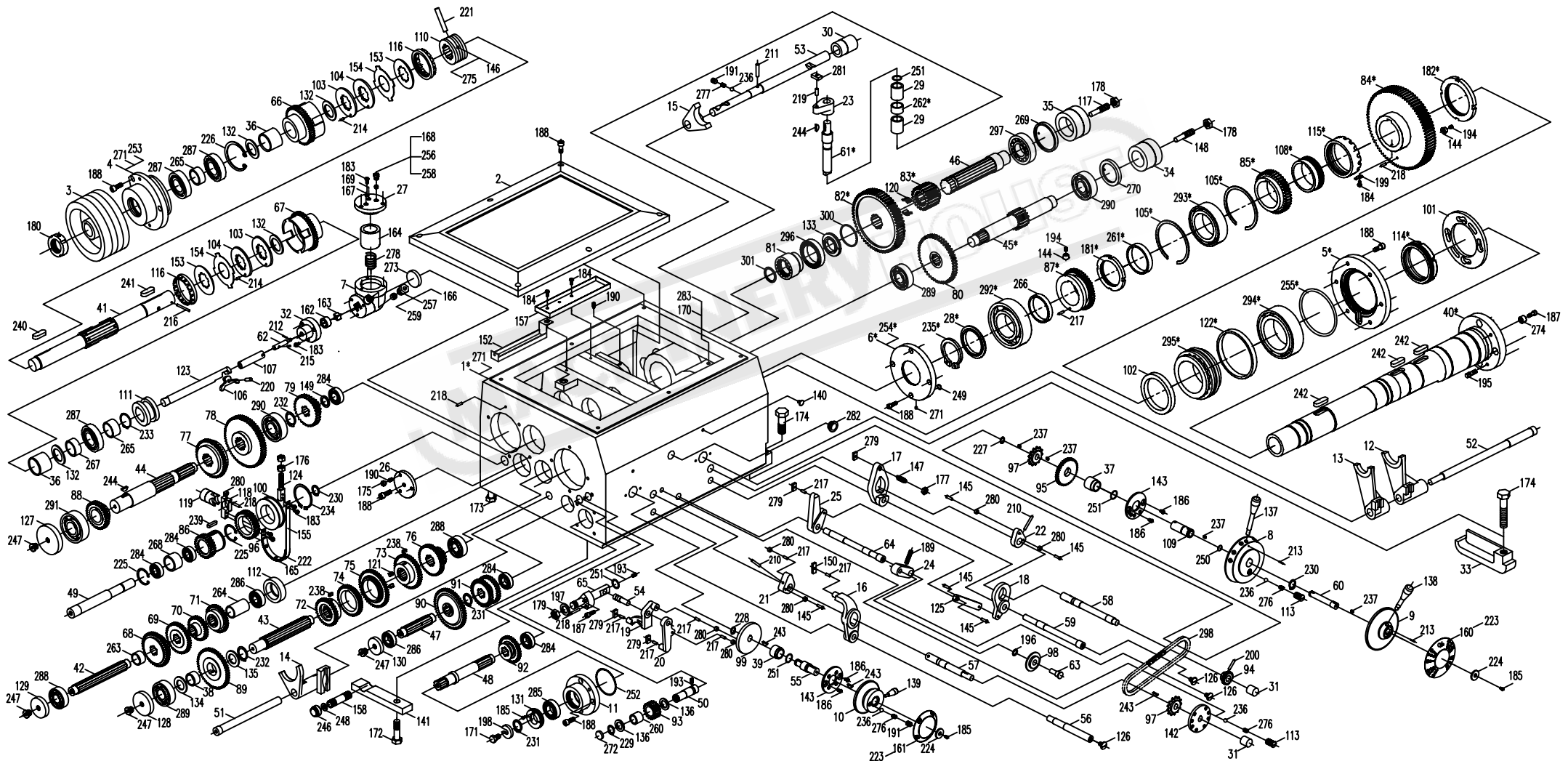

# 尾架 TAILSTOCK

Instructions Manual for CL-100 (L172)

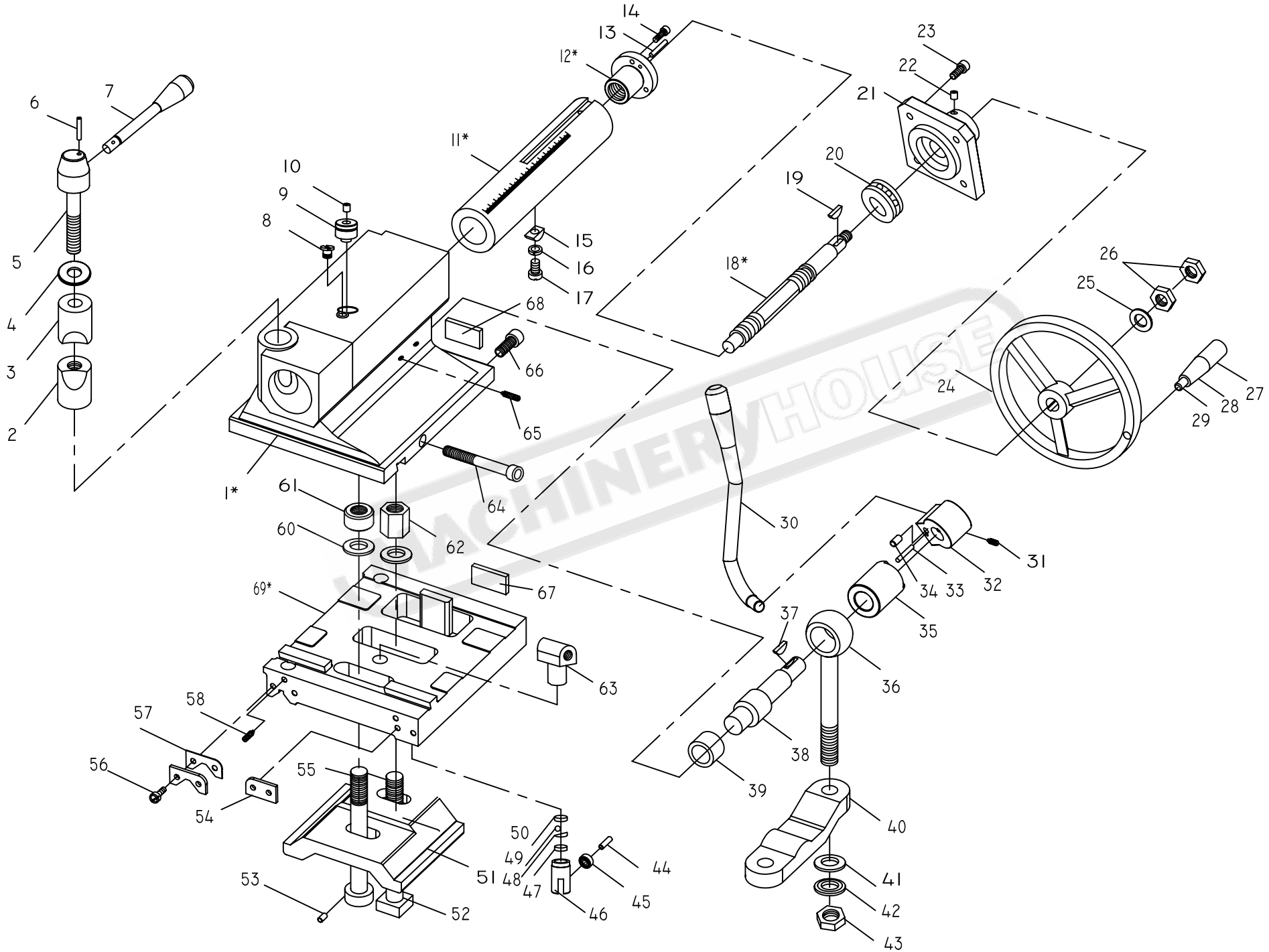

# 床鞍与刀架 CARRIAGE AND CROSSFEED

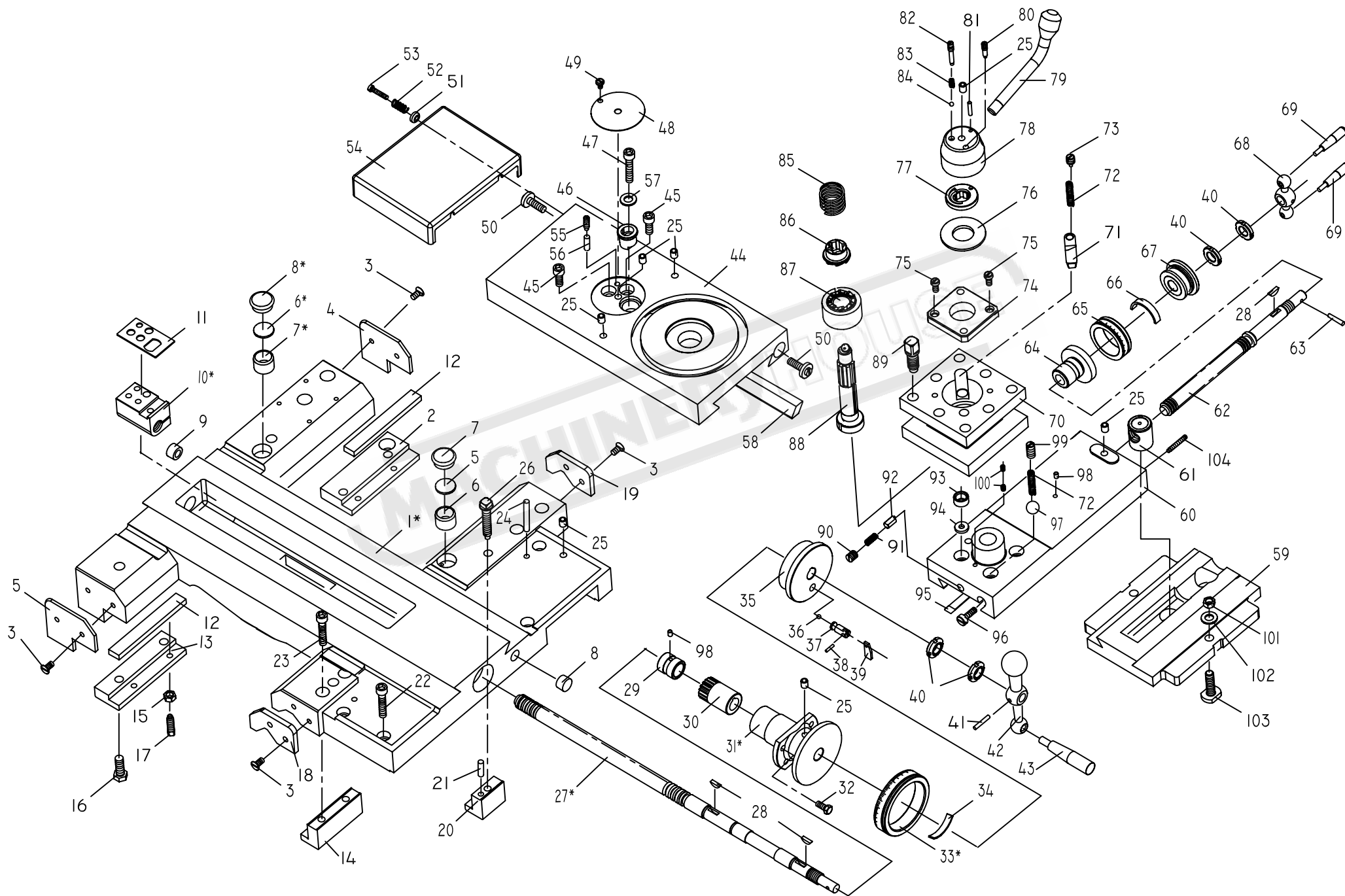

# 溜板箱 SLIDING BOX

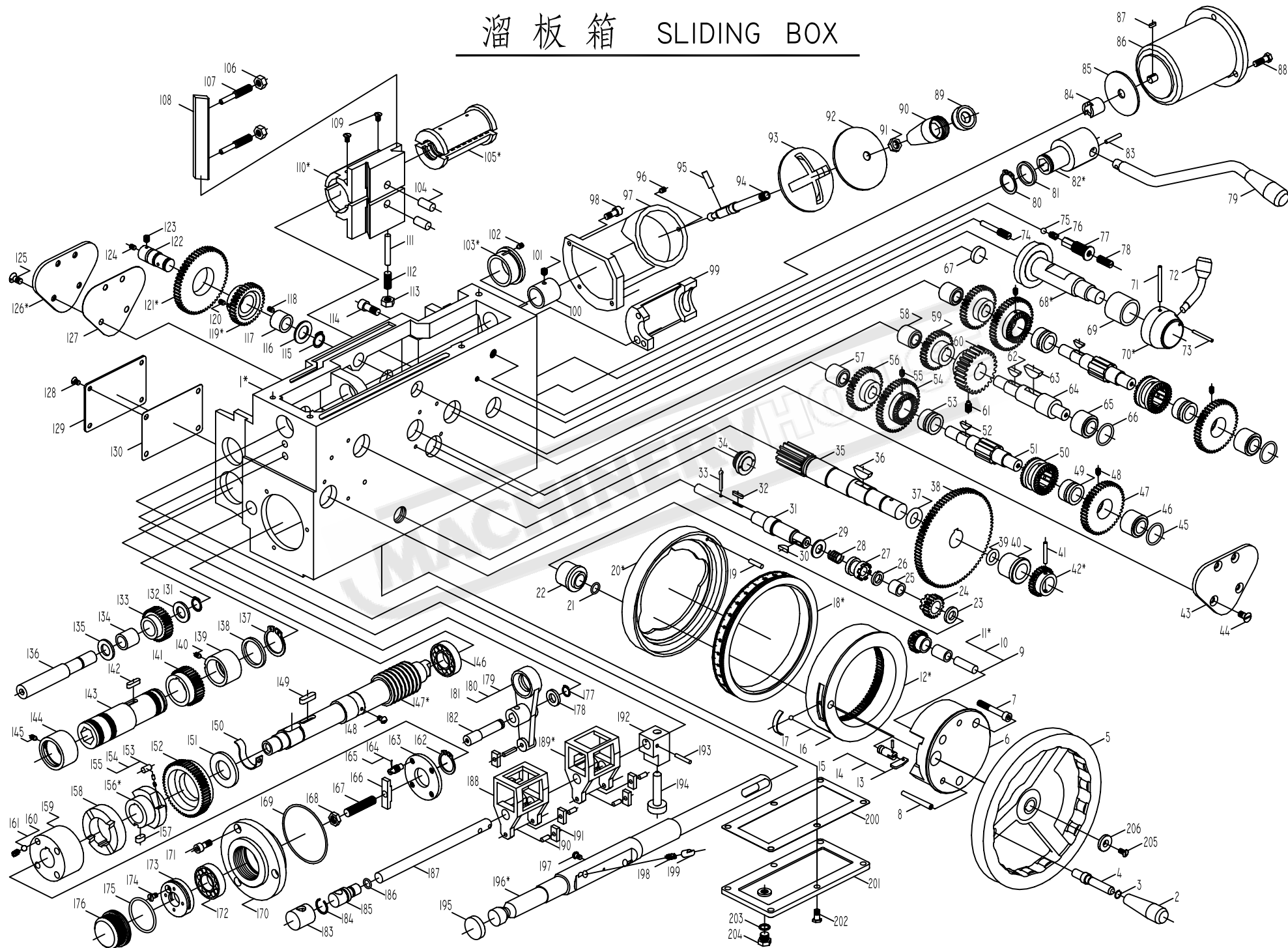

# 进给箱 GEAR BOX

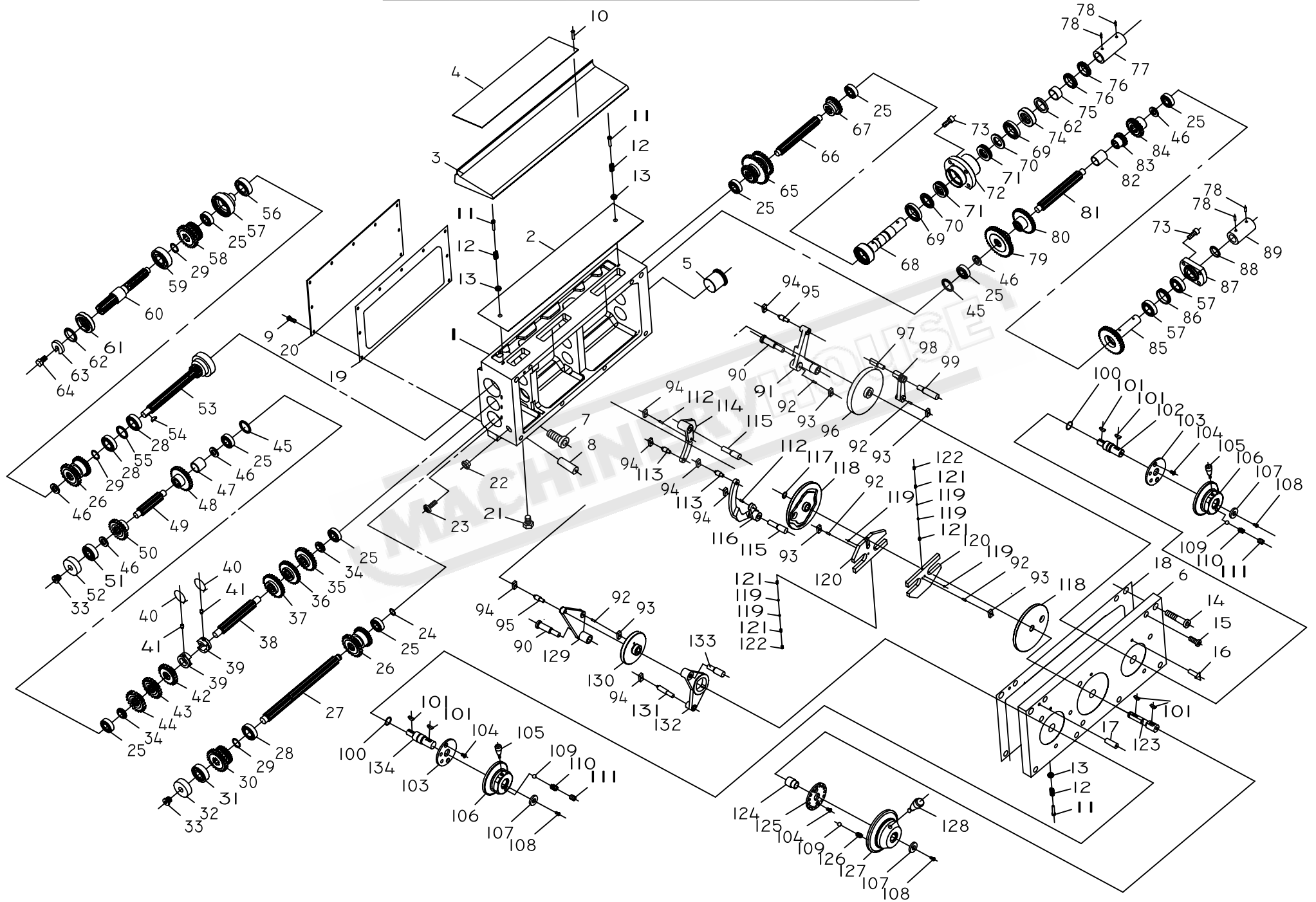

# 挂轮部件 CHANGE GEAR

床头箱输出轴

进给箱输入轴

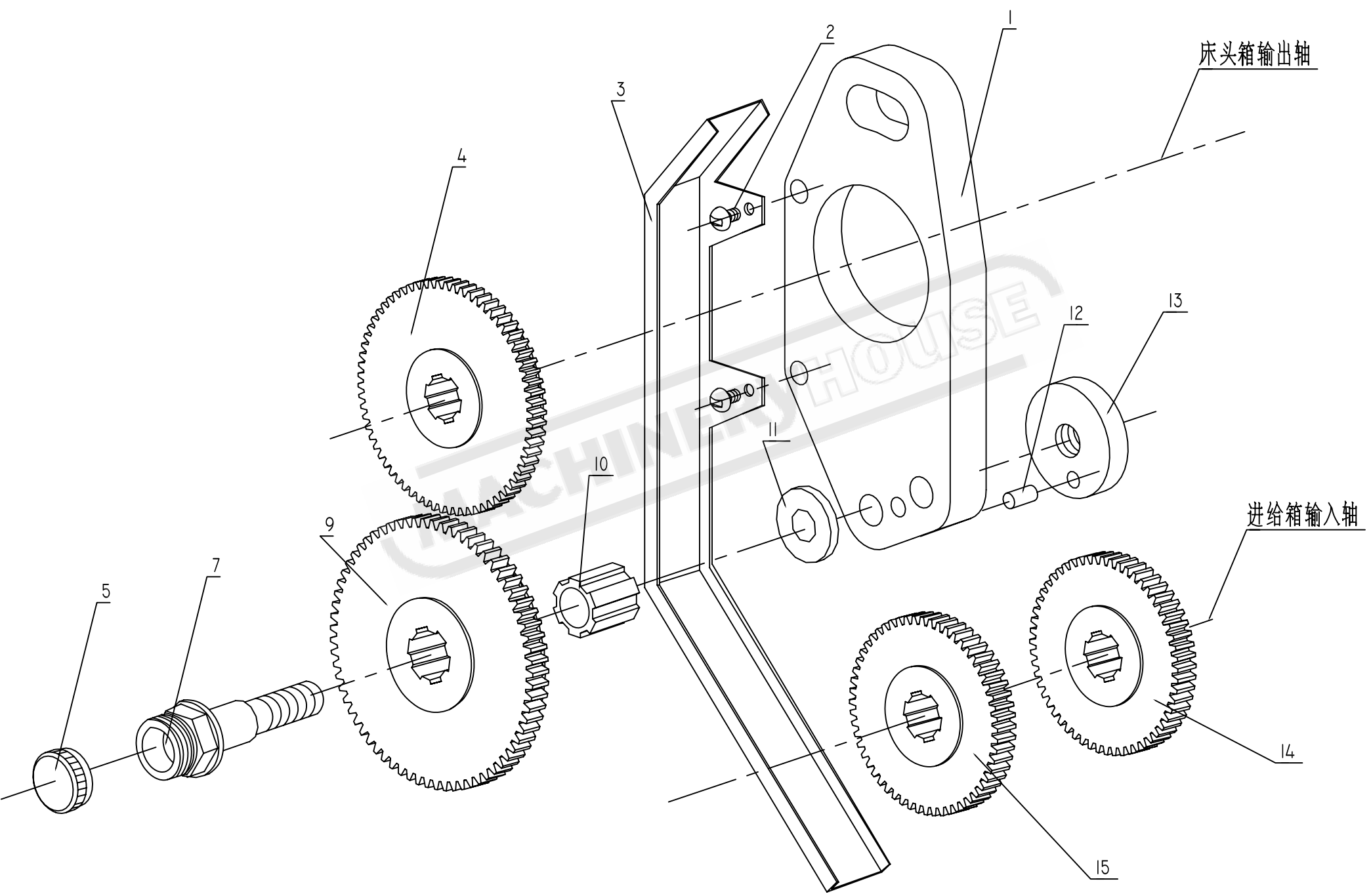



# 中心架 STEADY REST

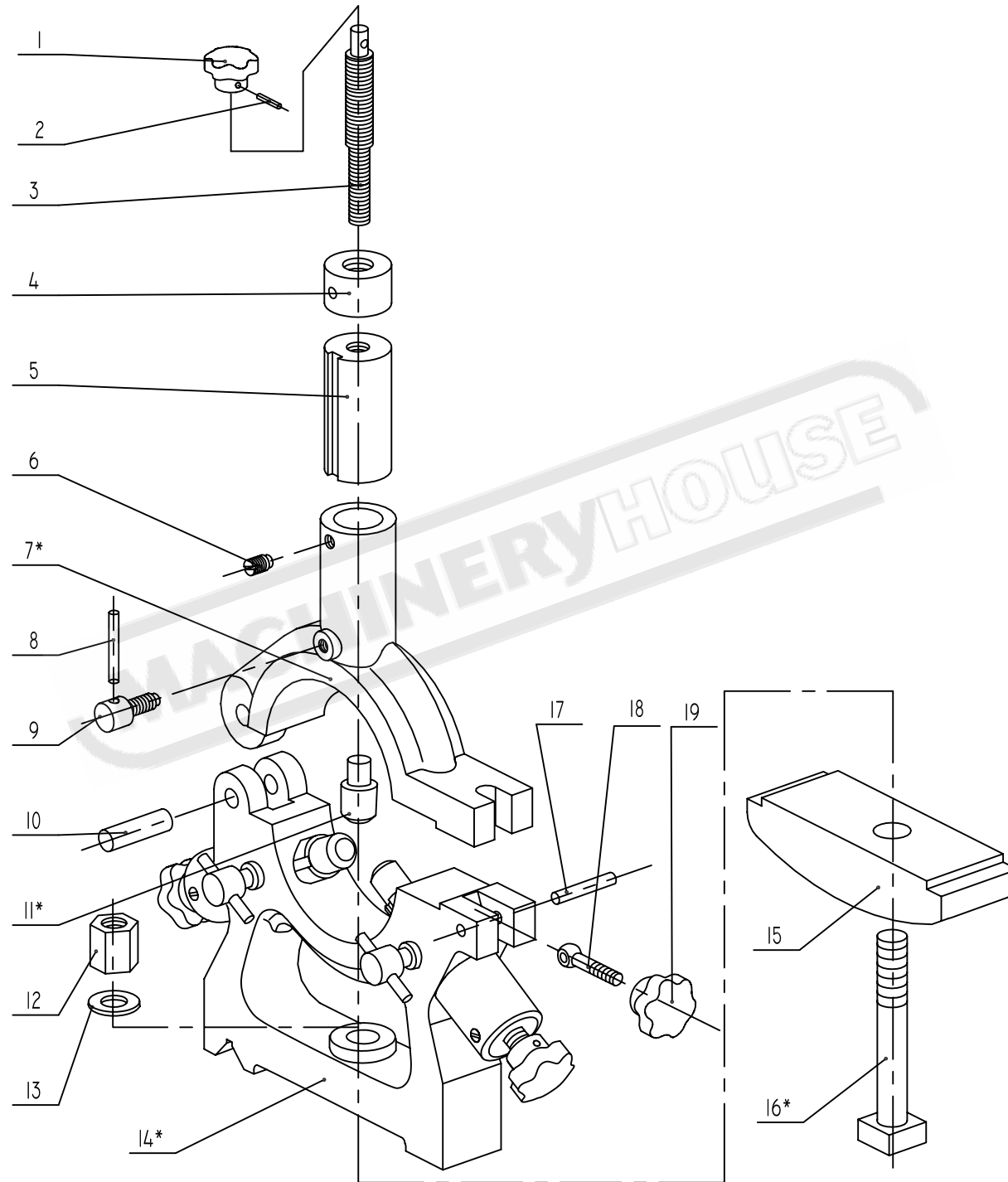

# 随行扶架 FOLLOW REST

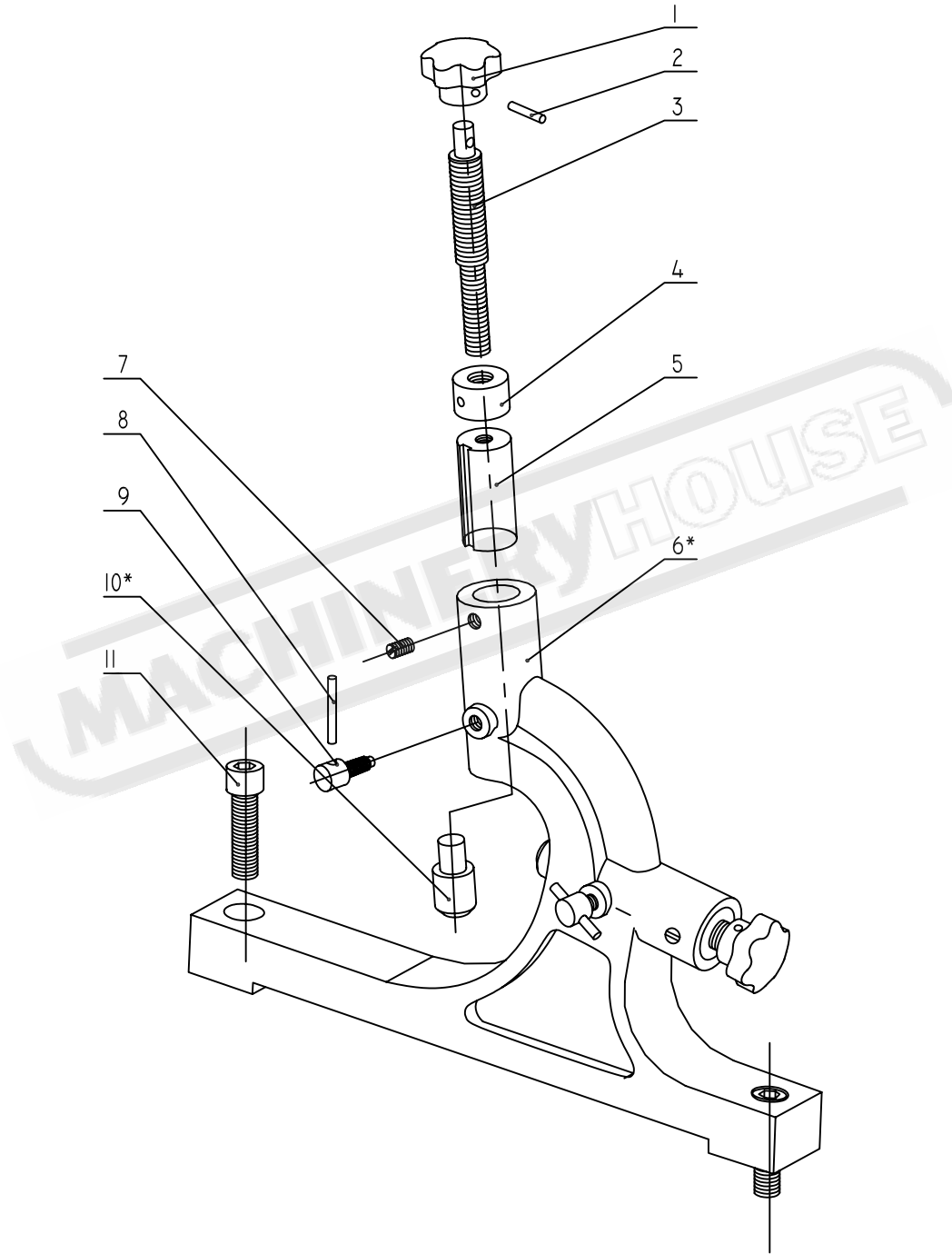



## 18. Element lists and disassembly draws of the main unit

### Important explanations:

1. The disassembling draw of the unit is a brief figure which shows the combinatorial relationship between parts, this only for reference in maintenance and repairing. And it's not the 'warranty for the sort and quantity of the parts because the draw is not a complete assembly drawing.
2. When purchasing and referring the repair parts, be sure to give clear indication of the type (model plate) and serial number (electrical capability plate) as well as the purchase time of our products, since the machine we produced may be improved and modified.
3. Not all of the modifies are showed in the disassembling draw and given in the list .We beg your understanding . Please contact with us when meeting such problems .

The disassembly draws and corresponding lists are presented in the order of the units.

### 18.1 Foundation base of lathe bed 床身

Since this 《Operating Instruction》 refers eight types machine with the maximum center distance range from 750mm~5000mm ,and in order to fulfil the changes of the main motor speed cause by different power supply frequency, these situations above-mentioned are all contained in this unit .So ,the varieties about this unit are more complex .For further particulars refer to the disassembly draw of this unit and table 18-1.

### 18.2 Headstock 床头

The major variety of this unit is the different among type A、 C and B .The spindle thru-bore diameter is 82mm[3"] in type B ,compare with type A and C the varieties are the elements fitted on spindle and the parts concerned with head box .More details in the disassembling draw of this unit and table 18-2.

### 18.3 Tailstock 尾座

The variety of tailstock is dependent mainly on the major parameter (swing over bed), furthermore there has change on leadscrew and nut pitch of the tailstock in British System machine . More variation in structure when the machine is fitted with tow-speed tailstock because of the gear-shift mechanism .More details in the disassembling draw of this unit and table 18-3.

### 18.4 Carriage and cross slide 刀架

The variety of carriage and cross slide is dependent mainly upon the major parameter



(swing over bed), furthermore, there has changes on longitudinal leadscrew and nut, transversal leadscrew and the pitch of corresponding nut. More variation in structure when the machine is fitted taper ruler. More details in the disassembly draw of this unit and table 18-4.

### 18.5 Apron 溜板箱

The apron has more varieties, there has different about left-handwheel and right-handwheel besides inch size machine. When the maximum workpiece length is exceeding 1500mm, the apron is then fitted with an assistant supporting sleeve on the leadscrew. More details in the disassembly draw of this unit and table 18-5.

### 18.6 Feed box 进给箱

The feed box has less varieties, the major change is related to the system of metric and inch. More details in the disassembly draw and table 18-6.

### 18.7 Transposing gear 变速机构

Although this unit is a small one, there has more varieties about it. More details in the disassembling draw and table 18-7.

### 18.8 Steady rest and follow rest

The variety about this unit is related to the major parameter (swing over bed). Machine type C is provided the special steady rest and follow rest fitting this type. Consultations in the disassembly draw and table 18-8 and 18-9.



Table 18-1 Lathe bed 床身部件

Serial No.	Name	Qty.	Part No.	Remarks
1*	Lathe bed 床身	1	PM-01001/750 PM-01001/750 G	Model A and B, 750mm[30"]
			PM-01001/1000 PM-01001/1000G	Model A and B, 1000mm[40"]
			PM-01001/1500 PM-01001/1500G	Model A and B, 1500mm[60"]
			PM-01001/2000 PM-01001/2000G	Model A and B 2000mm[80"]
			AC01001/2500 A2C01001/2500	Model C, 2500 mm[100"]
			AC01001/3000 A2C01001/3000	Model C, 3000 mm[120"]
			AC01001/4000 A2C01001/4000	Model C, 4000 mm[160"]
			AC01001/5000 A2C01001/5000	Model C, 5000 mm[200"]
2*	Screw 螺钉	6	M20x50 J21-1	Range from 750mm[30"]~ 1500mm[60"]
		10		Range from 2000mm[80"]~ 3000mm[120"]
		14		Range from 4000mm[160"]~ 5000mm[200"]
3*	Hind leg 后床脚	1	PM-01003	Range from 750mm[30"]~ 2000mm[80"]
			AC-01003	Range from 2500mm[100"]~ 5000mm[200"]
4*	Middle leg -1 中床脚-1	1	PM-01006	Range from 750mm[30"]~ 2000mm[80"]
			AC-01006-1	Range from 2500mm[100"]~ 5000mm[200"]
5*	Middle leg-2 中床脚-2	1	AC-01006-2	Range from 4000mm[160"],5000mm[200"]
6*	cap 盖	1	A-01055	Range from 750mm[30"]~ 1500mm[60"]
		2		Range from 2000mm[80"]~ 3000mm[120"]
		3		Range from 4000mm[160"], 5000mm[200"]



Continuous table 1

7	支架 Bearing bracket 托座	1	A-01005	Range from 750mm[30"]~ 2000mm[80"]
			AC-01005	Range from 2500mm[100"]~ 5000mm[200"]
8*	leadscrew 丝杆 大丝杆 导杆 螺母	1	A-01021/750	Metric 750mm[30"]
			A-01021/750-R	Metric 750mm[30"] right-handwheel
			A-01021/1000	Model A、metric model B 1000mm[40"]
			A-01021/1000-R	Metric 100mm[40"] right-handwheel
			A-01021/1500	Metric 1500mm[60"]
			A-01021/1500-R	Metric 1500mm[60"] right-handwheel
			A-01021/2000	Metric 2000mm[80"]
			A-01021/2000-R	Metric 2000mm[80"] right-handwheel
		1	AB-01021/750	Inch 750mm[30"]
			AB-01021/750R	Inch 750mm[30"] right-handwheel
			AB-01021/1000	Inch 1000mm[40"]
			AB-01021/100R	Inch 1000mm[40"] right-handwheel
			AB-01021/1500	Inch 1500mm[60"]
			AB-01021/1500R	Inch 1500mm[60"] right-handwheel
			AB-01021/2000	Inch 2000mm[80"]
			AB-01021/2000R	Inch 2000mm[80"] right-handwheel
		1	AC-01021/2.5m	Model C2500mm [100"]
			AC-01021/2.5mR	Model C 2500mm [100"] right-handwheel
			AC-01021/3000	Model C3000mm [120"]
			AC-01021/3M B	Model C 3000mm [120"] right-handwheel
			AC-01021/4000	Model C 4000mm [160"]
AC-01021/3M B	Model C 4000mm [160"] right-handwheel			
AC-01021/5000	Model C 5000mm [200"]			
9*	Feed rod 光杆	1	A-01022/750	Model A 、 B 750mm[30"]
			A-01022/1000	Model A 、 B 1000mm[40"]



Continuous table 2

			A-01022/1500	Model A 、 B 1500mm[60"]
			A-01022/2000	Model A 、 B 2000mm[80"]
			AC-01022/25m	Model C 2500mm [100"]
			AC-01022/3000	Model C 3000mm [120"]
			AC-01022/4000	Model C 4000mm [160"]
			AC-01022/5000	Model C 5000mm [200"]
10*	Operating lever 操纵杆	1	A-01023/750	Model A 、 B 750mm[30"]
			A-01023/1000	Model A 、 B 1000mm[40"]
			A-01023/1500	Model A 、 B 1500mm[60"]
			A-01023/2000	Model A 、 B 2000mm[80"]
			AC-01023/25m	Model C 2500mm [100"]
			AC-01023/3000	Model C 3000mm [120"]
			AC-01023/4000	Model C 4000mm [160"]
11*	●oil pan 油盘	1	A-01051/750,2000-1	Model A 、 B 750mm[30"]
			A-01051/1000	Model A 、 B 1000mm[40"]
			A-01051/1500	Model A 、 B 1500mm[60"]
		1	A-01051/750,2000-1	Model A 、 B 2000mm[80"]
		1	A-01051/2000	
		1	AC-01051/2.5mm-1	Model C 2500mm [100"]
		1	AC-01051/2.5mm-2	
		1	AC-01051/3mm-1	Model C 3000mm [120"]
		1	AC-01051/3mm-2	Model C 4000mm [160"]
		2	AC-01051/4mm-2	
		1	AC-01051/5mm-1	Model C 5000mm [200"]
		2	AC-01051/5mm-2	
12	Front leg 前脚	1	PM-01002/A	
13	Screw 螺钉	2	M8×12	
14	Cap 盖	1	A-01054	
15	Cap piece 罩盖	1	A-01073	
16*	Cover 罩	1	A-01071B or A-01072A	Swing over bed 400mm[16"]
			A <sub>1</sub> -01071B or A <sub>1</sub> -01072A	Swing over bed 500mm[20"]



Continuous table 3

17*	Cap 盖	1	A-01056/750, 1000	750mm[30"], 1000mm[40"]		
			A-01056/1500, 2000	1500mm[60"], 2000mm[80"]		
		AC-01056	2	Model C 2500mm [100"]		
			2	Model C 3000mm [120"]		
			3	Model C 4000mm [160"]		
3	Model C 5000mm [200"]					
18*	Cap 盖	1	AB-01053	Without electrical obstructing		
			AB-01053	With electrical obstructing		
19	Cap 隔板	1	A-01052B			
20*	Baffle 隔板	1	A-01076A	Without electrical obstructing		
	Cap 盖			With electrical obstructing		
21	Screw 螺钉	1	M6x10 J21-4			
22	Cap 盖	1	A-01057			
23	Pin 销	2	8x35 J41-2			
24	Bush 套	1	A-01012			
25	Bush 套	1	A-01013			
26	Pin 销	2	4x30 J44-1			
27	Screw 螺钉	1	M8x10 J22-1			
28	Socket head cap screw 内六角螺钉	1	M10x70 J21-9			
29	Socket head screw	1	M10x25 J21-9			
30*	Teeth bar 齿条	2	A-01024	750mm[30"]		
		1	A-01025			
		3	A-01024		1000mm[40"]	
		4	A-01024	1500mm[60"]		
		6	A-01024	2000mm[80"]		
		6	A-01024	Model C 2500mm [100"]		
		8		Model C 3000mm [120"]		
		11		Model C 4000mm [160"]		
		13		Model C 5000mm [200"]		
		1		A-01025	Model C 4000mm [160"]	
				Model C 5000mm [200"]		
		31*	Socket screw 内六角螺钉	6	M10x35 J21-9	Model A 、 B 750mm[30"]
				8		Model A 、 B 1000mm[40"]
12	Model A 、 B 1500mm[60"]					
10	Model A 、 B 2000mm[80"]					
12	Model C 2500mm [100"]					
16	Model C 3000mm [120"]					
20	Model C 4000mm [160"]					
	Model C 5000mm [200"]					





Continuous table 4

32*	Pin 销	6	8x45 J41-2	Model A 、 B 750mm[30"]
		8		Model A 、 B 1000mm[40"]
		12		Model A 、 B 1500mm[60"]
		10		Model A 、 B 2000mm[80"]
		12		Model C 2500mm [100"]
		16		Model C 3000mm [120"]
		20		Model C 4000mm [160"]
				Model C 5000mm [200"]
33	Cap 盖	1	A-01074	
34	Screwed pin	1	10x50 J41-3	
35	Pull rod	1	A-01033	
36	Handle	1	A-01031	
37	Holding screw	1	M8x16 J22-4	
38	Bush	1	A-01014	
39	Pin	1	5x30 J41-1	
40	Handle seating	1	A-01009	
41	Pin	1	10x50	
42	Split pin 开口销	2	3x16 J44-9	
43	Foundation adjusting bolt 地脚螺栓	6	M20x50 J21-1	Range from 750mm[30"]~ 1500mm[60"]
		10		Range from 2000mm[80"]~ 3000mm[120"]
		14		Range from 4000mm[160"], 5000mm[200"]
44	Nut 螺母	6	M20 J12-8	Range from 750mm[30"]~ 1500mm[60"]
		10		Range from 2000mm[80"]~ 3000mm[120"]
		14		Range from 4000mm[160"], 5000mm[200"]
45	Adapter 接头	1	A-01036	
46	Shaft 轴	1	A-01032	
47	Locking sleeve	1	25 J65-1	
48	Holding screw	1	M8x10 J22-4	
49	Bush	1	A-01011	
50	Rod end yoke	1	A-01008	
51	Bolt 螺栓	2	M20x80 J21-1	
52	Gemel 链条	4	Q72-2-31	
53	Nut 螺母	2	M8 J11-1	
54	Clout 扣圈	2	8 J51-1	
55	Nail 支钉	2	A-01037	



Continuous table 5

56	Data plate 标牌	1	A-01091	
57	Rivet 铆钉	4	2x4 J83-1	
58	Handle 手柄	1	B-(Cr)L10x80 Z14-1	
59	Hook 钩	1	A-01015	
60	Lock 锁	1	A-01016	
61	Pin 销	1	10x45 J41-1	
62	Pin 销	1	3x20 J41-1	
63	Socket head cap screw 内六角螺钉	2	M6x35 J21-9	
64	Pin 销	1	6x25 J44-1	
65	Pin 销	1	4x25 J44-1	
66	Pin 销	2	6x70 J44-1	
67	Holding screw 紧螺钉	1	M12x20 J22-10	
68	Key 键	1	8x56 J31-1A	
69*	Belt pulley 皮带轮	1	A-01007	Motor frequency : 50Hz
			AB-01007	Motor frequency : 60Hz
70	Holding screw	1	M12x20 J22-6	
71	Main motor 主电机	1	Y132M-4	7.5kW
			Y160M-4	11kW
			Y160L-4	15kW
72	Screw 螺钉	4	M10x35 J21-1	
73	Nut 螺母	2	M20 J11-1	
74	Washer 垫圈	3	20 J53-1	
75	Washer 垫圈	1	A-01082	
76	Big washer 大垫圈	1	20 J51-3	
77	Screw bolt 螺柱	1	A-01034	
78	V-belt 三角带	4	B-2210	Motor size: Y132M-4
			B-2184	Motor size: Y160M-4/ Y160L-4
79	Motor cabinet 电机柜	1	AB-01004	
80	Shaft 轴	1	A-01035	



Table 18-2

headstock

车头箱零件

Serial No.	Name	Unit	Part No.	Remark
1*	Box 箱体	1	A—02001 A	Model A、C Swing over bed 400[16"]
			A1-02001A	Model A、C Swing over bed 500[20"]
			AB—02001 A	Model B Swing over bed 400[16"]
			A1B-02001A	Model B Swing over bed 500[20"]
2	Top 箱盖	1	A—02002	
3	Belt pulley 皮带轮	1	A—02003	
4	Bearing seat 轴承座	1	A—02004	
5	Cap 盖	1	A—02005	Model A、C
			AB—02005	Model B
6	Cap 盖	1	A—02006	
7	Pump body 泵体	1	A—02007	
8	Handle seat 手柄座	1	A—02008	
9	Handle seat	1	A—02009	
10	Handwheel 手轮	3	A—02011	
11	Bearing seat 轴承座	1	A—02012	
12	Fork 拨叉	1	A—02013	
13	Fork	1	A—02014	
14	Fork	1	A—02015	
15	Fork	1	A—02016	
16	Lever 杠杆	1	A—02017	
17	Lever	1	A—02018	
18	Lever	1	A—02019	
19	Lever	1	A—02021	
20	Lever	1	A—02022	
21	Lever	1	A—02023	
22	Lever	1	A—02024	
23	Lever	1	A—02025	
24	Lever	1	A—02026	
25	Lever	1	A—02027	
26	Cap 盖	1	A—02028	
27	Cap	1	A—02029	
28*	Ring 环	1	A—02031	Model A、C
			AB-02031	Model B
29	Bush 套	2	A—02032	
30	Bush 套	1	A—02033	



Continuous table 1

31	Bush 套	2	A-02034	
32	Pump top 泵盖	1	A-02035	
33	Pressure plate 压板	1	A-02036	
34	Cap 盖	1	A-02037	
35	Cap 盖	1	A-02038	Model A, C
			AB-02038	Model B
36	Bush 套	2	A-02041	
37	Bush 套	1	A-02042	
38	Bush ..	1	A-02043	
39	Bush ..	1	A-2044A	
40*	Spindle 主轴	1	A-02051	Model A, C
			AB-02051	Model B
41	I shaft	1	A-02052	
42	II shaft	1	A-02053	
43	III shaft	1	A-02054	
44	IV shaft	1	A-02055	
45	V shaft	1	A-02056	Model A, C
			AB-02056	Model B
46	VI shaft	1	PM-02057	
47	IX shaft	1	A-02058	
48	X shaft	1	A-02059	
49	VIII shaft	1	A-02061	
50	XI shaft	1	A-02062	
51	XII shaft	1	A-02063	
52	XIII shaft	1	A-02064	
53	XIV shaft	1	A-02065	
54	Shaft 轴	1	A-02066	
55	Shaft ..	1	A-02067	
56	Shaft ..	1	A-02068	
57	Shaft ..	1	A-02069	
58	Shaft ..	1	A-02071	
59	Shaft ..	1	A-02072	
60	Shaft ..	1	A-02073	
61*	Shaft ..	1	A-02074	Swing over bed 400[16"]
			A-02074	Swing over bed 500[20"]
62	Shaft ..	1	A-02075	
63	Shaft ..	1	A-02076	
64	Shaft ..	1	A-02077	
65	Shaft ..	1	A-02078	
66	Gear 齿轮	1	A-02081	
67	Gear ..	1	A-02082	



Continuous table 2

68	Gear 齿轮	1	A—02083	
69	Gear	1	A—02084	
70	Gear	1	A—02085	
71	Gear	1	A—02086	
72	Gear	1	A—02087	
73	Gear	1	A—02088	
74	Gear	1	A—02089	
75	Gear	1	A—02091	
76	Gear	1	A—02092	
77	Gear	1	A—02093	
78	Gear	1	A—02094	
79	Gear	1	A—02095	
80	Gear	1	A—02096	
81	Gear	1	PM—02097	
82*	Gear	1	A—02098	Model A, C
			AB-02098	Model B
83	Gear	1	A—02099	
84	Gear	1	A—02101	Model A, C
			AB-02101	Model B
85	Gear	1	A—02102	Model A, C
			AB-02102	Model B
86	Gear	1	A—02103	
87	Gear	1	A—02104	Model A, C
			AB-02104	Model B
88	Gear	1	A—02105	
89	Gear	1	A—02106	
90	Gear	1	A—02107	
91	Gear	1	A—02108	
92	Gear	1	A—02109	
93	Gear	1	A—02111	
94	Gear	1	A—02112	
95	Gear	1	A—02113	
96	Gear	1	A—02114	
97	Chain gear 链轮	2	A—02121	
98	Tension wheel 张紧轮	1	A—02122	
99	Cam 凸轮	1	A—02123	
100	Brake wheel 制动轮	1	A—02124	
101	Ring 环	1	A—02131	
102	Bush 套	1	A—02132	
103	Shield ring 挡环	2	A—02133	
104	Shield ring	2	A—02134	



Continuous table 3

105	Shield ring 挡圈	2	A-02135	Model A, C
			AB-02135	Model B
106	Lever 杠杆	1	A-02136	
107	Bush 套	1	A-02137	
108	Bush	1	A-02138	Model A, C
			AB-02138	Model B
109	Bush	1	A-02139	
110	Bush	1	A-02141	
111	Bush	1	A-02142	
112	Bush	1	A-02143	
113	Bush	2	A-02144	
114	Screw cap 螺帽	1	A-02145	
115	Screw cap	1	A-02146	Model A, C
				Model B
116	Screw cap	2	A-02147	
117	Screw bolt 螺栓	1	A-02148	
118	Pulling plate 拉板	1	A-02149	
119	Pulling plate seating 拉板座	1	A-02151	
120	Key 键	1	A-02152	
121	Key 键	2	A-02153	
122	Sleeve 隔套	2	A-02154 A	Model A, C
			A-02154A	Model B
		1	AB-02154	
82	Gear	1	A-02098	
83	Gear	1	A-02099	
84	Gear	1	A-02101	
85	Gear	1	A-02102	
86	Gear	1	A-02103	
87	Gear	1	A-02104	
88	Gear	1	A-02105	
89	Gear	1	A-02106	
90	Gear	1	A-02107	
91	Gear	1	A-02108	
92	Gear	1	A-02109	
93	Gear	1	A-02111	
94	Gear	1	A-02112	
95	Gear	1	A-02113	
96	Gear	1	A-02114	
97	Chain gear 链轮	2	A-02121	
98	Tension wheel 张紧轮	1	A-02122	
99	Cam 凸轮	1	A-02123	



Continuous table 4

100	Brake wheel	制动轮	1	A—02124	
101	Ring	环	1	A—02131	
102	Bush	套	1	A—02132	
103	Shield ring	挡环	2	A—02133	
104	Shield ring	挡环	2	A—02134	
105	Shield ring	挡圈	2	A—02135	
106	Lever	杠杆	1	A—02136	
107	Bush	套	1	A—02137	
108	Bush	套	1	A—02138	
109	Bush	套	1	A—02139	
110	Bush	套	1	A—02141	
111	Bush	套	1	A—02142	
112	Bush	套	1	A—02143	
113	Bush	套	2	A—02144	
114	Screw cap	螺帽	1	A—02145	
115	Screw cap	螺帽	1	A—02146	
116	Screw cap	螺帽	2	A—02147	
117	Screw bolt	螺帽	1	A—02148	
118	Pulling plate	拉板	1	A—02149	
119	Pulling plate seating	拉板座	1	A—02151	
120	Key	键	1	A—02152	
121	Key	键	2	A—02153	
122	Sleeve	隔套	2	A—02154	
123	Pull rod	拉杆	1	A—02155	
124	Pull rod	拉杆	1	A—02156	
125	Link lever	连杆	1	A—02157	
126	Screw	螺帽	4	A—02158	
127	Block	堵	1	A—02159	
128	Block	堵	1	A—02161	
129	Block	堵	1	A—02162	
130	Block	堵	1	A—02163	
131	Block	堵	1	A—02164	
132	Pillow	垫	4	A—02165	
133	Ring	环	1	PM-02508	
134	Pillow	垫	1	A—02167	
135	Pillow	垫	1	A—02168	
136	Pillow	垫	2	A—02169	
137	Handlebar	手把	1	A—02172	
138	handlebar	手把	1	A—021273	
139	handlebar	手把	3	A—02174	
140	Indicator	指示标	5	A—02175/1	



Continuous table 5

141	Pressure plate 压板	1	A—02176	
142	Strongback 定位板	1	A—02177	
143	Strongback	2	A—02178	
144	Balance weight 平衡块	Circa 6	A—02179	
145	Pin 销	5	A—02181	
146	Pin	2	A—02182	
147	Eccentric pin 偏心销	1	A—02183	
148	Screw bolt 螺栓	1	A—02184	
149	Pillow 垫	1	A—02185	
150	Sliding piece 滑块	1	A—02186	
151	Indicator 指示标	1	A—021475/1	
152	Oil pan 油盘	1	A—02191	
153	Friction disc 摩擦盘	16	A—02192	
154	Friction disc	14	A—02193	
155	Brake band 制动带	1	A—02194	
157	Oil pan 油盘	2	A—02196	
158	Drain line 放油管	1	A—02197	
160	Plate 标牌	1	A—02202	
161	Plate	1	A—02203	
162	Outer rotor 外转子	1	A—02211	
163	Inner rotor 内转子	2	A—02212	
164	Oil filter 滤油网	1	A—02221	
165	Friction disc 摩擦盘	1	A—02231	
166	Oil pipe 油管	1	A—02241	
167	Oil pipe	1	A—02242	
168	Oil pipe	1	A—02243	
169	Oil pipe	1	A—02244	
170	Oil pipe	1	A—02245	
171	Small hex head bolt 小六角头螺栓	1	M12x20 J21-1	
172		1	M16x60 J21-1	
173		2	M16x80 J21-1	
174		3	M20x60 J21-1	
175	Oblate hex nut 六角扁螺母	3	M8 J11-2	
176		2	M12 J11-2	
177		1	M12x1.25 J11-2	
178		2	M16x1.5 J11-2	
179		1	M20 J11-2	
180	Locking nut 压块紧锁螺母	1	M36x1.5 J14-6	
181		1	GM80x1.5 J14-6	





Continuous table 6

182		1	GM100x1.5 J14-6	
183	Cylinder head screw 圆柱头螺钉	10	M6x16 J21-8	
184	Half round screw 半圆头螺钉	4	M6x10 J21-4	
185	Sunk head screw 沉头螺钉	3	M5x12 J21-6	
186		4	M6x12 J21-6	
187	Socket head cap screw 内六角螺钉	3	M8x25 J21-9	
188		24	M10x25 J21-9	
189	Taper-end holding screw 锥形端固定螺钉	1	M10x40 J22-4	
190	Taper-end holding screw 锥形端固定螺钉	4	M8x20 J22-6	
191	Flat-end holding screw 平端固定螺钉	2	M12x14 J22-3	
193	End holding screw 平端固定螺钉	2	M8x14 J22-5	
194	Socket head holding screw 内六角固定螺钉	6	M8x1x10 J22-9	
195	Square head screw 四方头螺钉	2	M10x25 J21-7	
196	Washer 垫圈	1	12 J51-1	
197		1	20 J51-1	
198	Slot washer 开口垫圈	1	A12-40 J51-5	
199	Single-ear stopping washer 单耳止距垫圈	1	6 J55-3	
200	Taper pin 圆锥销	1	6x30 J41-1	
210		2	6x45	
211	Inner screwed taper pin 内螺紋圆锥销	1	8x40 J41-2	
212	Straight pin 圆柱销	1	3x10 J44-1	
213		2	3x16 J44-1	
214		2	5x10 J44-1	
215		1	5x25 J44-1	
216		1	5x40 J44-1	
217		8	6x16 J44-1	
218		4	6x25 J44-1	
219		1	8x20 J44-1	
220		1	8x28 J44-1	
221		1	12x70 J44-1	
222	Sunk head rivet 沉头铆钉	3	3x8 J82-167	
223	Rivet for plate 板用铆钉	18	2x4 J83-1	
224	Shaft end check ring 轴端挡圈		B30 J64-1	
225	Circlip for hole 孔用弹性挡圈	2	47 J62-3	
226		1	80 J62-3	
227	Circlip for shaft 轴用弹性挡圈	1	16 J62-2	
228		1	18 J62-2	
229		1	22 J62-2	
230		2	25 J62-2	
231		2	30 J62-2	
232		2	35 J62-2	



Continuous table 7

233		1	40	J62-2	
234		1	58	J62-2	
235		1	75	J62-2	
236	Steel ball 钢球	4	10	GB308—64	
237		4	5x5x10	J31-1A	
238		2	6x6x16	J31-1A	
239		1	8x7x35	J31-1A	
240	Flat key 普通平键	1	12x8x50	J31-1A	
241		1	12x8x70	J31-1A	
242		3	16x10x50	J31-1A	
243		3	5x19	J33-1A	
244	Semicircular key 半圆键	2	6x19	J33-1A	
246	Seal nut 封口管螺母	1	G1/2"	G34-2	
247	Inner hex oil plug 六角油塞		M16x1.5	G38-4	
248	Rubber blanket 橡胶毯	1	I-1,10	66HG4-330-66	
249		1	12x1.9	G51-2	
250	"O"-ring O型密封圈	1	16x2.4	G51-2	
251		4	25x2.4	G51-2	
252		1	80x3.1	G51-2	
253		1	125x3.1	G51-2	
254	"O"-ring	1	135x3.1	G51-2	
255		1	180x5.7	G51-2	
256	Pipe junction 管接头	3	6	G91—1	
257		1	10	G91—1	
258		3	6	G91—2	
259	Closed joint insert 闭合型	1	10	G91—2	
260	Shaft sleeve 轴套	1	B-Cu 30x25	Q41-1	
261	Sleeve for shaft 内衬套	1	J-80x16	Q43—1	
262*		1	28x35x20	Q43-1-J	Swing over bed 400[16"]
			28x35x60	Q43-1-J	Swing over bed 500[20"]
263	Sleeve	1	30x37x20	Q43-1-J	
264		1	30x37x60	Q43-1-J	
265	隔套	2	40x48x25	Q43-1-J	
266		1	75x85x14	Q43-1-J	
267		1	40x48x20	Q43-1-J	
268		1	38x47x30	Q43-1-J	
269	Salver 顶盘	1	90	Q55-8	
270		1	80	Q55-8	



Continuous table 8

271	Plug 堵塞	4	6 Q56-1	
272		1	25 Q56-1	
273	Plug	1	50 Q56-1	
274	Fitting pin 定位销	1	170 Q71-1-34	
275	Pressure spring 压力弹	2	0.8x5x16 Q81-1	
276		3	1.6x8x18 Q81-1	
277		-1	1.6x10x25 Q81-1	
278		1	2x25x40 Q81-1	
279	Sliding piece 滑块	4	12 Q99-1	
280		7	B-12 Q99-1	
281		1	16 Q99-1	
282	Roundness oil leveler 油封	2	20 R51-2	
283	Holder 油封支持器	1	0.5x25 R95-1	
284	Bearing	5	25x47x12 105	
285		1	30x55x13 106	
286		2	25x52x15 205	
287		3	48x80x18 208	
288		2	25x62x17 305	
289		2	30x72x19 306	
290		2	35x80x21 307	
291		1	40x90x23 308	
292		1	75x130x25 D215	
293		Double-lined axipetal cylinder roller bearing 双列同心短圆柱 滚子轴承	1	80x125x34 D3182116
294	滚子轴承	1	100x150x37 1D3182120K	
295	Bilateral thrust angle- contact bearing 双向推力角接触轴承	1	100x150x60 5D2268120	
296	Single-lined taper roller bearing 单列圆锥滚子轴承	1	45x85x21 7209	
297		1	40x90x35.5 7608	
298	Single-row bush roller chain 单排套筒滚子链	1	Pitch 12.7(bicycle chain) overall length 46 sections	
300	Wiresteel ring 钢丝挡圈	1	70 J62-6	
301	Pillow 垫	1	PM-02509	
△	Stopping washer 止限 垫圈	1	AB-02041	Add in model B



Table 18-3 Tailstock

Serial No.	Name	Qty	Part No.	Remark
1*	Tailstock body. 尾座体	1	A-03001	Model A、B、C Swing over bed 400mm [16"]
			A <sub>1</sub> -03001	Model A、B、C Swing over bed 400mm [16"]
2	Lower brake-rod-shoe 下闸块	1	A-03009	
3	Upper brake-rod-shoe 上闸块	1	A-03008	
4	Washer 垫圈	1	A-03042	
5	Screw bolt 螺栓	1	A-03032	
6	Pin 销	1	5x25 J44-1	
7	Handle 手柄	1	A-03033	
8	Screw 螺钉	1	M5x10 GB833-67	
9	Key 键	1	A-03035	
10	Oil cup 油杯	1	10 R71-1	
11*	Quill 套筒	1	A-03021	Metric lathe
			AB-03021	Inch lathe
			A-02021-A	Metric and Inch double-scale
12*	Nut 螺母	1	A-03005	Metric lathe
			A-03005-n	Inch lathe
13	Pin 销	1	5x25 J41-1	
14	Socket head cap screw 六角头螺栓	3	M6x20 J21-9	
15	Key 键	1	A-03036	
16	Elastic collar 弹性垫圈	1	10 J54-1	
17	Screw 螺栓	1	M10x16 J21-8	
18*	Leadscrew	1	A-03022	Metric and Inch lathe
			A-03022-n	Lathe of the whole inch
19	Semicircular key 半圆键	1	22 J33-1A	
20	Thrust bearing 推力轴承	1	8205 GB301-84	
21	Bearing seat 轴承座	1	A-03004	
22	Oil cup 油杯	1	10 R71-1	
23	Socket head cap screw	4	M8x20 J21-9	
24	Handle	1	8-250x22 Z54-2	
25	Washer 垫圈	1	16 J51-1	
26	Nut	2	M16 J11-1	
27	Handle sleeve 手柄套	1	Z13-1-J-31	
28	Handle lever 手柄杆	1	Z13-1-J-32	
29	Wiresteel ring 钢丝圈	1	Z13-1-J-33	
30	Handle	1	A-03033	
31	Holding screw 紧螺栓	1	M8x16 J22-6	
32	Handle seating 手柄座	1	A-03006	



Continuous table 1

33	Pin	1	5x30 J41-1	
34	Pin	1	8x16 J41-1	
35	Bush 套	1	A-03011	
36	Screw	1	A-03037	
37	Semicircular key 半圆键	1	5x19 J33-1A	
38	Eccentric pin 偏心轴	1	A-03023	
39	Bush	1	A-03012	
40	Pressure plate 压板	1	A-03031	
41	Spherical washer 球面垫圈	1	20 J53-1	
42	Taper washer 锥面垫圈	1	20 J53-2	
43	Nut	1	M20x1.5 J11-2	
44	Pin	4	A-03044	
45	Annular ball bearing 同心球轴承	4	17	
46	Bush	4	A-03043	
47	Rubber blanket 橡胶垫	4	A-03047	
48	Pillow 垫	4	A-03045	
49	Steel ball 钢球	4	10 GB308-64	
50	Pillow 垫	4	A-03046	
51	Pressure 压板	1	A-03003	
52	Screw	1	A-03039	
53	Pin	1	5x14 J41-1	
54	Chip scraper 刮屑板	2	A-03049-B	
55	Screw	1	A-03038	
56	Screw	8	M6x10 J21-4	
57	Chip scraper	2	A-03048-B	
58	Holding screw 紧固螺钉	4	M6x18 J22-3	
59	Bottom plate 底板	1	A-03002	
60	Washer	2	20 J51-1	
61	Nut	1	A-03041	
62	Nut	1	M20 J11-3	
63	Nut	1	A-03007	
64	Socket head cap screw	2	M12x120 J21-9	
65	Holding screw	2	M8x25 J22-6	
66	Socket head cap screw	2	M12x28 J21-9	
67	Plate 标牌	1	PQ-03088	
68	Plate ..	1	PQ-030889	



Table 18-4 Saddle and carriage

Serial No.	Name	Qty	Part No.	Remark
1*	Saddle 鞍	1	A-05001-A	
			A-05001-R	Right-handwheel
2	Hind pressure plate 后压板	1	A-05042A	
3	Screw	8	M8x16 J21-6	
4	Chip scraper	1	A-05064-A	
5	Chip scraper	1	A-05063-A	
6*	Felt gasket 毛毡垫	2	A-05083	Subassembly of oil cup in model A、C
7*	Oil cup	2	A-05058	
8*	Oil cup cap 油杯盖	2	A-05067	
△	Oil cup cap 油杯盖	(2)	AB-05411	Subassembly of oil cup in model B
△	Oil cup cover 油杯罩	(2)	AB-05412	
△	Rotating cover 转盖	(2)	AB-05413	
△	Felt gasket 毛毡垫	(2)	AB-05083	
9	Block 块	2	A-05091A	
10*	Nut	1	A-05011	Metric lathe
			AB-05011	Inch lathe
11	Clout 垫片	1 group	A-05069	Quantity and thickness confirmed by assembling
12	Board 板	2	A-05044A	
13	Hind pressure plate 后压板	1	A-05041A	
14	Front pressure plate 前压板	2	A-05006	
15	Nut	4	M10 J11-1	
16	Screw	4	M10x40 J21-1	
17	Screw	4	M10x30 J22-2	
18	Clip scraper 刮屑板	1	A-05061-A	
19	Clip scraper	1	A-05062-A	
20	Pressure plate	1	A-05043	
21	Pin	1	8x25 J44-1	
22	Socket head screw	4	M12x50 J21-9	
23	Socket head screw	4	M12x60 J21-9	
24	Pin	2	8x60 J41-2	
25	Oil cup	5	10 R71-1	
26	Screw	1	M12x70 J21-7	
27*	Leadscrew 丝杆	1	A-05021	Metric lathe
			AB-05021	Inch lathe
28	Semicircular key	3	5x19 J33-1A	
29	Bush 套	1	A-05007	
30	Gear	1	A-05031	
31*	Supporting 支承座	1	A-05003	Metric lathe
			AB-05003	Inch lathe



Continuous table 1

32	Screw	4	M8x20 J21-1	
33*	Scale ring 刻度环	1	100x18x100-n Q67-4-J-32	Used in metric lathe
			AB-05041	Used in Inch lathe
34	Elastic slice 弹性片	1	80~125 Q67-4—J-33	
35	Inner ring 内环	1	A-05004A	
36	Steel ball 钢球	1	8 GB308-64	
37	Pin	1	A-05049	
38	Pin	1	3x12 J44-1	
39	Handle bar 把手	1	A-05051	
40	Nut	2	M18x1.5 J14-4	
41	Pin	1	5x30 J41-1	
42	Handle	1	(Cr)L14x65 Z42-1	
43	Handle	1	(Cr)L10x80x22 Z11-1	
44	Cross slide 下刀架	1	A-05002	
45	Socket head cap screw	2	M10x25 J21-9	
46	Bush	1	A-05046	
47	Socket head cap screw	2	M10x55 J21-9	
48	Cap	1	A-05071	
49	Screw	1	M6x10 J21-4	
50	Screw	2	M10x30 J22-11	
51	Pillow 垫	2 (6)	A-05066	Altogether 6 pieces, 4 pieces used in other unit
52	Spring 弹簧	2	1.6x10x25 Q81-1	
53	Screw	2	M6x30 J21-8	
54	Guard shield	1	A-05065	
55	Holding screw 护罩	1	M8x25 J22-5	
56	Pin	1	6x25 J44-1	
57	Washer 垫圈	1	A-05048	
58	Gib 垫条	1	A-05005	
59	Top slide 中刀架	1	A-04001	
60	上刀架	1	A-05002	
61	Nut	1	A-04011	
62	Leadscrew	1	A-04031	
63	Pin	1	5x30 J41-1	
64	Eccentric sleeve 偏心套	1	A-04004	
65	Scale ring 刻度环	1	60x18x100-n Q67-4-J-32	
66	Elastic slice 弹性片	1	50~60 Q67-4-J-31	
67	Inner ring	1	6x18 Q67-4-J-31	
68	Handle	1	A-04021	
69	Handle	2	(Cr)L6x50x16 Z11-1	
70	Tool post 刀架	1	A-04041	



Continuous table 2

71	Pin	1	A-04044	
72	Spring	2	1.6x8x75 Q81-1	
73	Holding screw	1	A-04052	
74	Capping 压盖	1	A-04045	
75	Screw	2	M8x16 J21-8	
76	Washer	1	A-04056	
77	Check ring 挡圈	1	A-04048	
78	Handle seating	1	A-04046	
79	Handle	1	A-04047	
80	Screw	1	A-02049	
81	Pin	1	5x25 J44-1	
82	Screw	1	A-04055	
83	Spring	1	1x6x25 Q81-1	
84	Steel ball 钢球	1	6 GB308-64	
85	Spring	1	A-04062	
86	Zygote 接合子	1	A-04061	
87	Cam	1	A-04043	
88	Shaft	1	A-04042	
89	Holding screw	1	M16x40 J22-1	
90	Holding screw	1	M12x14 J22-3	
91	Spring	1	(Y) 1x8x25 Q81-1	
92	Pin	1	A-04054	
93	Bush	4	A-04059	
94	Pillow	1	A-04058	
95	Gib	1	A-04003	
96	Screw	1	A-04053	
97	Steel ball	1	3/4" GB308-65	
98	Oil cup	2	6 R71-1	
99	Holding screw	1	M12x25 J22-3	
100	Holding screw	2	M6x8 J22-3	
101	Nut	2	M12 J11-1	
102	Pillow	2	12 J51-1	
103	Screw	2	A-04051	
104	Holding screw	1	M10x35 J22-5	





Table 18-5 Apron

Serial No.	Name	Qty	Part No.	Remark
1*	Apron 溜板箱	1	A-06001-A	Model A
			AB-06001	Model B
			AC-06001	Model C , 2500~5000mm
			A-06001-R	Right-handwheel,750~2000mm
			PM-06101/F	Right-handwheel,2500~5000mm
2	Handle sleeve 手柄套	1	85 Z13-1-J-31	
3	Wiresteel ring 钢丝圈	1	1.2x13 Z13-1-J-33	
4	Handle lever 手柄杆	1	85x20 Z13-1-J-32	
5	Handwheel 手轮	1	A-06005	
6*	Supporting	1	A-06002	Model A
			AB-06002	Model B
7	Screw	3	M8x55 J21-9	
8	Pin	2	8x60 J41-2	
9	Pin	1	12x40 J44-1	
10	Shaft sleeve	1	18x25 Q41-1	
11*	Gear	1	A-06073	Metric
			AB-06073	Inch
12*	Gear	1	A-06074A	Metric
			AB-06074A	Inch
13	Handle bar 把手	1	A-05051	
14	Pin	1	A-05049	
15	Pin	1	5x19 J33-1	
16	Steel ball	1	6 GB308-64	
17	Elastic slice 弹性片	1	80~125 Q67-4-J-33	
18*	Index ring 分度环	1	A-06088	Metric
			AB-06088	Inch
19,180	Pin	1	6x25 J44-1	
20*	Seat ring 座圈	1	A-06006	Metric
			AB-06006	Inch
			A-06006-R	Right-handwheel
21	Seal ring 密封圈	1	18x2.4 HG4-333	
22	Bush	1	A-06011	
23,178	Pillow	2	A-06115	
24	Gear	1	A-06071	
25	Shaft sleeve	1	20x16 Q41-1	



Continuous table 1

26	Pillow	1	A-06114	
27	Clutch 离合器	1	A-06112	
28	Spring	1	1.6x18x25 Q81-1	
29	Washer	1	14 J51-1	
30,52	Semicircular key	3	5x19 J33-1	
31	I shaft	1	A-06051	
32	Flat key 平键	1	4x4x20 J31-1	
33	Split pin 开口销	1	4x25 J44-9	
34	Circular oil leveler 圆油杯	1	20 R51-2	
35	II shaft	1	A-06052	
36,63	Semicircular key	2	8x32 J33-1	
37	Seal ring	1	32x3.5 HG4-333	
38	Gear	1	A-06069	
39	Seal ring	1	25x2.4 HG4-333	
40	Oiliness bushing 油杯	1	A-06031	
41	Pin	1	5x35 J41-1	
42*	Gear	1	A-06072	Metric
			AB-06072	Inch
43, 126*	Cap	2	A-06121	750~2000mm
			AC-06121	2500~5000mm
44,125	Screw	8	M8x16 J21-6	
45,66	Seal ring	3	35x3.1 HG4-333	
46,65	Oiliness bushing	3	A-06032	
47,54	Gear	4	A-06066	
48,55,96, 140,145	Holding screw	7	M6x10 J22-4	
49,53	Bush	4	A-06025	
50	Zygote 轴套	2	A-06089	
51	III(VI)shaft	2	A-06053	
56	Gear	2	A-06065	
57,58	Oiliness bushing	3	A-06033	
59	Gear	1	A-06064	



Continuous table 2

60*	Wormwheel	1	A-06021	
			A-06021-R	Right-handwheel
61	定位螺钉 Locating screw	1	M8x16 J22-6	
62	Semicircular key	1	6x22 J33-1	
64	V shaft	1	A-06055	
67	Stopples 堵塞	1	25 Q56-1	
68*	VII shaft	1	A-06056	750~2000mm
			A-06056-R	Right-handwheel, 750~2000mm
			AC-06056	2500~5000mm
			AC-06056-R	Right-handwheel, 2500~5000mm
69	Shaft sleeve	1	32x25 Q41-1	
70*	Handle seating	1	A-06099	
			A-06099-R	Right-handwheel
71	Pin	1	5x60 J41-1	
72	Handle	1	A-06102	
73	Pin	1	4x30 J41-1	
74	Screw	1	A-06095	
75	Steel ball	1	8 GB308-64	
76,198	Spring	4	1.6x8x22 Q81-1	
77	Screwed bush 螺套	1	A-06127	
78,112	Screw	2	M10x25 J22-3	
79	Handle	1	A-06101	
80,162	Check ring 挡圈	2	30 J62-2	
81	Sleeve 隔套	1	30x37x4 Q43-1-J	
82*	Handle seating	1	A-06098	
			A-06098-R	Right-handwheel
83,193	Pin	2	5x30 J41-1	
84	Splicing sleeve 接套	1	A-06107	Diameter of motor shaft $\Phi 14$
		1	A-06107A	Diameter of motor shaft $\Phi 11$
85	Pillow	1	A-06141	
86	Quick speed motor	1		
87	Flat key	1	4x4x12 J31-1	Motor belt
88	Bolt 螺钉	3	M8x25 J21-1	
89	Button seating 按钮	1	A-06105	
90	Handle header 手柄头	1	A-06104	
91	Nut	1	M12x1.25 J11-2	



Continuous table 3

92	Cap	1	A-06151	
93	Cap	1	A-06012	
94	Handle	1	A-06103	
95	Pin	1	8x25 J44-1	
97	Guard shield 护罩	1	A-06003	
98,171	Screw	8	M8x20 J21-9	
99	Bracket 支架	1	A-06043	
100	Shaft sleeve	1	B35x35 Q41-1	
101,123	Screw	2	M8x10 J22-4	
102	Screw	1	M6x16 J22-4	Used in lathe 1.5M,2M
103*	Bush	1	A-06026	Used in lathe 1.5M,2M 2500~5000mm
			AC-06026	
104	Pin	2	12x25 J44-1	
105*	Split-nut 对合螺母	1	A-06022	Metric ,750~2000mm
			AB-06022	Inch ,750~2000mm
			AC-06022	Metric ,2500~5000mm
			AC-06022-n	Inch ,2500~5000mm
106,113	Screw 螺母	3	M10 J11-1	
107	Screw	2	A-06094	
108	Gib	1	A-06111	
109,128	Screw	8	M6x10 J21-6	
110*	Split-nut seating 对合螺母座	1	A-06004	750~2000mm
			A-06004-R	Right-hand wheel, 750~2000mm
			AC-06004	2500~5000mm
			PM-06004/B	Right-handwheel,2500~5000mm
111	Pin	1	8x50 J44-1	
114	Screw	1	M10x25 J21-9	
115	Check ring	1	20 J62-2	
116	Washer	1	20 GB848-66	
117	Shaft sleeve	1	28gax20 Q41-1	
118,120,124	Holding screw	3	M6x8 J22-3	
119*	Gear	1	A-06067	Right-handwheel
			A-06067-R	
121*	Gear	1	A-06068	Right-handwheel
			A-06068-R	



Continuous table 4

122	IVshaft	1	A-06054	
127	Paper pillow 纸垫	1	A-06132	
129	Cap	1	A-06122	
130	Paper pillow	1	A-06133	
131	Check ring	1	18 J62-2	
132,135	Pillow	2	A-06109	
133	Gear	1	A-06062	
134	Shaft sleeve	1	25x25 Q41-1	
136	IXshaft	1	A-06058	
137	Check ring	1	38 J62-2	
138	Sleeve 隔套	1	38x47x4 Q43-1-J	
139	Bush 套	1	A-06024	
141	Gear	1	A-06061	
142	Flat key	1	6x6x25 J31-1	
143	Feed rod sleeve 光杆套	1	A-06082	
144	Bush	1	A-06023	
146,172	Bearing	2	25x52x16.5 7205	
147*	VIIshaft	1	A-06057	Right-handwheel
			A-06057-R	
148,197	Screw	4	M6x10 J21-4	
149	Flat key	1	8x7x30 J31-1	
150	Oil strap 油杯	1	A-06123	
151	Pillow	1	A-06108	
152	Gear	1	A-06063	
153	Spring	3	0.3x3x12 Q81-1	
154	Pin	3	4 C31-1-35	
155	Roller 滚子	3	8 C31-1-34	
156*	Clutch body 离合 器体	1	A-06083A	Right-handwheel
			A-06083-R	
157	Flat key	1	8x7x16 J31-1	
158	Zygote 结合子	1	A-06084	
159	Zygote	1	A-06085	
160	Steel ball	4	10 GB308-64	
161	Spring	4	1.6x8x32 Q81-1	



Continuous table 5

163	Pillow	1	A-06086	
164	Wire 铁丝		Φ0.8	
165	Screwed stopple 丝堵	4	A-06096	
166	Sliding board 滑板	1	A-06087	
167	Holding screw	1	M12x60 J22-9	
168	Nut	1	M12 J11-2	
169	Seal ring	1	95x3.1 HG4-333	
170	Bearing seat	1	A-06007	
173	Screwed loop	1	A-06097	
174,205	Screw	2	M5x12 J21-6	
175	Seal ring	1	56x3.5 HG4-333	
176	Cover 帽	1	A-06125	
177	Check ring	1	14 J62-2	
179	Lever 杠杆	1	A-06013	
181,191	Sliding piece 滑块	5	12 Q99-1	
182	Shaft	1	A-06113	
183	Cap	1	A-06161	
184	Check ring	1	22 J62-4	
185	Oil plug 油塞	1	A-06116A	
186	Seal ring	1	16x2.4 HG4-333	
187	Shaft	1	A-06091	
188	Transmission fork 拨叉	1	A-06041	
189*	Transmission fork	1	A-06042 A-06042-R	Right-handwheel
190	Pin	4	6x14 J44-1	
192	Interlock pin seating 互锁销座	1	A-06009	
194	Interlock pin 互锁销	1	A-06092	
195	Stopples 堵塞	1	35 Q56-1	
196*	Controlling shaft 操纵轴	1	A-06081 A-06081-R	Right-handwheel
199	Pin	3	A-06106	
200	Paper pillow	1	A-06131	
201	Cap	1	A-06008	
202	Screw	6	M8x16 J21-1	





Table 18-6 fced box 进给箱

Serial No.	Name	Qty	Part No.	Remark
1	Box 箱体	1	A-07001	
2	Cover 盖	1	A-07133	
3	Cap	1	A-07132A	
4*	Plate 标牌	1	A-07151	Used in metric lathe
			AB-07151	Used in Inch lathe
5	Bush	1	A-07012	
6	Top 箱盖	1	A-07002A	
7	Socket head cap screw	2	M12x50 J21-9	
8	Pin	2	10x60 J41-2	
9	Screw	9	M8x12 J21-4	
10	Rivet for plate 标牌铆钉	24	2x4 J83-1	
11	Screw	4	M6x16 J21-8	
12	Spring	4	1x10x10 Q81-1	
13	Pillow	4	A-05056	
14	Screw bolt 螺杆	2	A-07126A	
15	Socket head cap screw	6	M10x30 J2109	
16	Indicator 指示标	3	A-02175	
17	Pin	2	8x50 J41-2	
18	Paper pillow	1	A-07156	
19	Paper pillow	1	A-07155	
20	Cover 盖	1	A-07131	
21	Oil plug 油塞	1	M12x1.25 G38-2A	
22	Circular oil lever	1	20 R51-2	
23	Screw	3	M10x30 J21-11	
24	Shield ring for shaft 轴衬	1	17 J62-2	
25	Bearing 轴衬	9	203 GB276-86	
26*	Gear	2	A-07066	
27	Shaft	1	A-07039	
28	Bearing	5	105 GB276-86	
29	Shield ring for shaft	3	25 J62-2	
30	Gear	1	A-07064	
31	Bearing	1	304 GB276-86	
32	Cap	1	A-07099	
33	Oil plug 油塞	2	M16x1.5 G38-4A	
34	Adjuster 调整圈	2	A-07122	
35	Gear	1	A-07067	
36	Gear	1	A-07068	
37	Gear	1	A-07069	
38	Shaft	1	A-07036	





Continuous table 1

39	Bush 套	2	A-07119
40	Wire 铁丝	2	Φ0.8x150
41	Holding screw	2	M8x10 J22-5
42	Gear	1	A-07071
43	Gear	1	A-07072
44	Gear	1	A-07073
45	Cage ring 隔圈	2	A-07127
46	Washer	5	A-07124
47	Bush	1	25x32x28 Q43-1-J
48	Gear	1	A-07063
49	Shaft	1	A-07035
50	Gear	1	A-07062
51	Bearing	1	303 GB276-86
52	Cap	1	A-07098
53	Gear shaft	1	A-07032
54	Semicircular key	1	4x19 J33-1A
55	Cage ring	1	A-07128
56	Bearing	1	205 GB276-86
57	Gear	1	A-07065
58	Gear	1	A-07061
59	Bearing	1	305 GB276-86
60	Shaft	1	A-07031
61	Gear	1	A-07079
62	Gear	1	A-07061
63	Spring washer	2	35 J51-1
64	Slot washer	1	A12-40 J51-5
65	Gear	1	A-07074
66	Shaft	1	A-07033
67	Gear	1	A-07075
68	Gear shaft	1	A-07034
69	Bearing	2	7000106 GB276-86
70	Washer	2	A-07123
71	Thrust ball bearing	2	D8106 GB301-86
72	Bearing seat	1	A-07004
73	Socket head cap screw	8	M10x25 J21-9
74	Cap	1	A-07125
75	Bush	1	A-07015
76	Nut	2	A-07121
77	Bush	1	A-07095
78	Pin	4	6x10 J41-1
79	Gear	1	A-07076



Continuous table 2

80	Gear	1	A-07077	
81	Shaft	1	A-07037	
82	Bush	1	A-07014	
83	Gear	1	A-07078	
84	Gear	1	A-07079	
85	Gear shaft	1	A-07038	
86	Bush	1	A-07096	
87	Cap	1	A-07003	
88	Washer	1	G51-1 25	
89	Bush	1	A-07096	
90	Shaft	2	A-07044	
91	Lever	1	A-07009	
92	Pin	5	J44-1 5n6×14	
93	Sliding piece	6	Q99-1 B-10	
94	Sliding piece	7	Q99-1 12	
95	Shaft	2	A-07111	
96	Cam	1	A-07093	
97	Drawable shaft	1	A-07114	
98	Lever	1	A-07011	
99	Shaft	1	A-07047	
100	“●” felt ring	2	G51-2A 25×2.5	
101	Key	6	J33-1A 5×19	
102	Shaft	1	A-07043	
103	Locating washer	2	Z34-2 22	
104	Screw	6	J21-6 M6×12	
105	Handle bar	2	A-02174	
106	Handwheel	2	A-02011	
107	Check ring	3	J64-1 B30	
108	Screw	3	J21-6 M5×12	
109	Steel ball	3	GB308-64 10	
110	Spring	2	Q81-1 YI-1.6×8×18	
111	Screw	2	J22-3 M12×14	
112	Pin	2	J44-1 6n6×14	
113	Shaft	2	A-07113	
114	Lever	1	A-07005	
115	Shaft	2	A-07046	
116	Lever	1	A-07006	
117	Circlip for shaft	1	J62-2 16	
118	Cam	2	A-07092	
119	Steel ball	6	GB308-64 5	
120	Sliding board	2	A-07094	





Continuous table 1

7	支架 Bearing bracket 托座	1	A-01005	Range from 750mm[30"]~ 2000mm[80"]
			AC-01005	Range from 2500mm[100"]~ 5000mm[200"]
8*	leadscrew 丝杆 大丝杆 导杆 螺母	1	A-01021/750	Metric 750mm[30"]
			A-01021/750-R	Metric 750mm[30"] right-handwheel
			A-01021/1000	Model A、metric model B 1000mm[40"]
			A-01021/1000-R	Metric 100mm[40"] right-handwheel
			A-01021/1500	Metric 1500mm[60"]
			A-01021/1500-R	Metric 1500mm[60"] right-handwheel
			A-01021/2000	Metric 2000mm[80"]
			A-01021/2000-R	Metric 2000mm[80"] right-handwheel
		1	AB-01021/750	Inch 750mm[30"]
			AB-01021/750R	Inch 750mm[30"] right-handwheel
			AB-01021/1000	Inch 1000mm[40"]
			AB-01021/100R	Inch 1000mm[40"] right-handwheel
			AB-01021/1500	Inch 1500mm[60"]
			AB-01021/1500R	Inch 1500mm[60"] right-handwheel
			AB-01021/2000	Inch 2000mm[80"]
			AB-01021/2000R	Inch 2000mm[80"] right-handwheel
		1	AC-01021/2.5m	Model C2500mm [100"]
			AC-01021/2.5mR	Model C 2500mm [100"] right-handwheel
			AC-01021/3000	Model C3000mm [120"]
			AC-01021/3M B	Model C 3000mm [120"] right-handwheel
			AC-01021/4000	Model C 4000mm [160"]
AC-01021/3M B	Model C 4000mm [160"] right-handwheel			
AC-01021/5000	Model C 5000mm [200"]			
9*	Feed rod 光杆	1	A-01022/750	Model A 、 B 750mm[30"]
			A-01022/1000	Model A 、 B 1000mm[40"]



Table 18-7 Transposing gear

Serial No.	Name	Qty	Part No.	Remark
1*	Transposing gear	1	A-08001	Model A 、 C metric lathe Swing over bed 400mm [16"]
			A1-08001	Model A 、 C metric lathe Swing over bed 500mm [20"]
			AB-08001	Used in Inch lathe
2	Screw	2	M6x10 J21-4	
3	Oil baffle	1	A-08031	Used in metric lathe
			AB-08031	Used in Inch lathe
4*	Gear	1	A-08042	Model A 、 C metric lathe Swing over bed 400mm [16"], Model B metric lathe swing over bed 400mm[16"]、 500mm[20"]
			A1-08042	Model A 、 C metric lathe 500[20"]
			AB-08044	Used in Inch lathe
5	Cap	1	A-08025	
6				
7	Shaft	1	A-08021	Used in metric lathe
			AB-08021	Used in Inch lathe
8				
9*	Gear	1	A-08043	Model A 、 C metric lathe Swing over bed 400mm [16"], Model B metric lathe Swing over bed 400mm[16"]
			A1-08043	Model A 、 C metric lathe swing over bed 500mm[20"]
			A1B-08046-t	Model B metric lathe swing over bed 500mm [20"]
			AB-08045	Used in Inch lathe
10	Spline housing	1	A-08011	
11	Pillow	1	A-08024	
12	Pin	1	8x6 J44-1	
13	Nut	1	A-08023	
14*	Gear	1	A-08044	Model A 、 C metric lathe Swing over bed 400mm [16"], Model B metric lathe .Swing over bed 400[16"]、 500[20"]
			A1-08044	Model A 、 C metric lathe swing over bed 500[20"]
			AB-08042	Used in Inch lathe





Table 18-8 Steady rest

Serial No.	Name	Qty	Part No.	Remark
1*	Handle	3	A-10105	
2	Pin	3	4x30 J41-1	
3	Screw bolt	3	A-10113	
4	Screwed bush	3	A-10115	
5	Sliding bush	3	A-10114	
6*	Holding screw	3	M10x12 J22-6	
7*	Steady rest upside	1	A-10101	
8*	Pin	3	6x45 J44-1	
9	Screw	3	A-10112	
10*	Pin	1	16x55 J44-1	
11	Resist head	3	A-10104	
12	Nut	1	M20 J11-3	
13	Pillow	1	20 J51-1	
14	Steady rest downside	1	A-10101	Model A 、 B swing over bed 400mm[16"]
			A1-10101	Model A 、 B swing over bed 500[20"]
15	Pressure plate	1	A-10103	
16	Screw	1	A-10111	
17	Pin	1	10x55 J44-1	
18	Screw	1	M12x60 J23-3	
19	Handle	1		



## 19 Easy worn parts

The easy worn parts of the machine are listed in table19-1. The other worn parts not listed in the table are universal parts of all type machine referred in this 《Operating Instruction》.

Table 19-1 Easy worn parts

Serial No.	Part No.	Part name	Material	Heat treatment	Qty	Remark
1	A02041	Bushing	ZQSn6-6-3		2	
2	A02136	Lever	45	Local G48	1	
3	A02192	Clutch disc	15	S0.5~ C0.6	16	
4	A02193	Clutch disc	15	S0.5~ C0.6	14	
5	A02194	Brake band	65Mn		1	
6	A02211	Outer rotor of trochoid pump	Sintered powder iron basic metal		1	
7	A02212	Inner rotor of trochoid pump	Sintered powder iron basic metal		1	
8	A02231	Brake friction disc	Canvas with iron sand		1	
9	A05011	Slide nut	ZQSn6-6-3		1	Model A,B Inch lathe
	AB05011					Model B Inch lathe
10	A06021	Worm wheel	ZQSn6-6-3		1	
11	A06022	Split-nut	ZQSn6-6-3		1	Model A,B Metric lathe
	AC06022					Model C
	AB05022					Model B Inch lathe
12	A08011	Spline bushing	ZQSn6-6-3		1	
13	J22-1	Screw M16x40	35		8	
14	Q99-1 12	Slide block	HT300		1	
15	Q99-1 16	Slide block	HT300		11	
16	S77-1 M5	Center MT5	T8	Tip C59 Shank C40	2	